

Distributor Handbook



Enagic Philippines, Inc.
Effective August 28, 2024

Any practice or policy previously circulated and implemented contrary to this document shall be considered superseded. Enagic® reserves the right to revise, modify and amend any of these terms and conditions any time, and the Buyer/Distributor agree to abide by the most recent version of this Handbook.

Table of Contents

How to become an Enagic Distributor	2
Letter to the New Distributor	2
Definition of Terms	3
Distributor's Responsibilities	4
Instructions on Filling out Applications	5-7
Single Payment	8-9
- Distributor	8-9
- User	8-9
- Business Entity	9
Enagic E-Payment Plan Distributor	10-11
- Enagic Payment Chart	12-13
- Enagic Payment Policies and Procedure	14-16
Other Payment Method	17-19
- Mail Order/Telephone Order	17
- Credit Card	18-19
- Credit Card Installment Plan	18-19
- Order via E-mail	19
Tokurei (Good Samaritan)	20-21
Processing of Order, Orders of Accessories and Other Information	22-24
Rules for Self-Purchase Enroller Sales (Revised)	25
Application Forms Usage	26-27
General E-mail Information & Bank Details	28
Shipping Information	29
Seminar Room Booking	29
General Commission Information, Special Point	30-32
Commission Payout Schedule	33
Commission Procedures & Requirements	34
Consignment Process	35
Consignment Rules and Regulations	35-36
Commission Offset for Consignments	37
Cancellation of Distributorship	37
Official Receipts	38-39
Joint Business Venture Terms and Conditions	39
Releasing of BIR 2307 and Submission of Official Receipt	40
Releasing of E-payment Commissions	40
Commission Chart	41
Basic 8point Commission Structure	42-51
Ukon DD and Sigma 8-point Commission Structure (Pass-up system)	52
Educational Bonus	53
6A Step Up Bonus, Group Bonus, Title Incentive	54-55
Additional Rule for Achieving 6A Rank	56-57
Incentives Relating to Additional Rule for 6A	57
6A 8 Level Monthly and Quarterly Group Incentive	58
Collection Rate & Bonuses Chart	59
Machine Repair Instruction	60-62
Warranty	63-64

How can one become an Enagic Distributor

To become an Enagic Distributor, the applicant must: (1) be sponsored by an existing Enagic Distributor in good standing; and (2) either purchase a Kangen Machine or become a Tokurei [Good Samaritan] applicant.

Letter to the New Distributor

Congratulations and welcome to Enagic Philippines, Inc. (the “Company”)!

You have made the first step towards success.

This Handbook contains detailed information regarding the application procedure, as well as answers to general questions that you may have. You can utilize this Handbook not only for purposes of conducting your own business, but also as a tool for training your team. Remember, the more you know, the more you grow!

Should you have any question that was not covered in this Handbook, you should follow the steps outlined herein before contacting the Company. First, you need to call your up line, or your up line’s up line (your 6A would be best). Second, you need to check the Company’s website. After exhausting the first two options and your question remains unanswered, you may call the Company for guidance/assistance. Keep in mind that you entered a pre-existing team, and you are NOT alone. You just need to reach out and connect to the hundreds, if not thousands, of people in your group who are willing and ready to help you build your own team and business.

****Please read this Handbook in its entirety before submitting your application to avoid any issue/misinterpretation****



facebook@enagic.ph

Definition of Terms

Whenever used in this Handbook, the following terms shall be construed to mean as:

1. Accessories – items related to the Machine that can be bought in the Enagic Office.
2. Alternate Payor – someone who is willing and ready to pay in behalf of Buyer.
3. BIR – Bureau of Internal Revenue.
4. Buyer –buyer of the Machines who may either be a Distributor or User.
5. Company or Enagic – Enagic Philippines, Inc.
6. Distributor – someone who purchases the Machine and distributes the same for business.
7. Enagic Office – 16th Floor, A.T. Yuchengco Centre, 26th and 25th St., Bonifacio Global City, Taguig City.
8. E-friends - official magazine of Enagic International including monthly updates and promotions.
9. E-Payment – Enagic Payment Plan wherein Machines will be paid through the issuance of post-dated checks.
10. Handbook – this Distributor’s Handbook which is considered as part of the Manual for Enagic Distributors.
11. Machine – LeveLuk water treatment Machines
12. Pay-Off Commissions - closing commission for Distributors with installment payment programs. Commission balance, if any, will be released upon full payment of the Machine. However, such will depend on the status of the distributor if he/she has delinquent accounts or unliquidated consignments. The pay-off/bonus commissions put on hold will automatically be offset/applied to any unsettled account/s of the Distributor concerned.
13. SP – Special Points or additional bonus payments earned whenever a direct sale is made by a Distributor (except for Tokurei distributors).
14. Sponsor – a Distributor in good standing who introduces and assists a Buyer in purchasing Machine/s.
15. User – one who purchases a Machine without intention of becoming a Distributor.

Distributor's Responsibilities

As a Distributor you have many responsibilities that are not only vital to your success, but also important in ensuring that all your interactions with the Company are as productive as possible. It is very important for you to understand that you are not working for Enagic Philippines, Inc. or vice versa, but on your own. The role of the Company is simply to ensure that an orderly system among all of the "business" owners and Distributors is in place, and to fulfill the orders that are generated through your hard work. To reach optimal success, please fully understand and be prepared to fulfill the following responsibilities:

1. Fully educate yourself with the necessary information regarding the Machines, health information, commissions, complete order processing, and general business practices.
2. Train and fully educate all Distributors in your downline.
3. Answer all the questions that your group members may have. More difficult questions should be directed to your 6A Distributors. The Company should be contacted only as a last resort.
4. Do not make any health, monetary, or false claims regarding the Machine, its sale and other related matters. If you have knowledge of anyone making the above claims, please report them to the Company **immediately**.
5. The treated water must never be sold to individuals or companies. Donations for said water is likewise not acceptable. Anyone who is violating these rules must likewise be reported to the Company immediately.
6. The Distributor must be able to provide an Official Receipt within seven to fifteen (7-15) days from receipt of commissions. Distributors shall be informed by email of the amount of and the date when the commissions have been remitted.
7. Read, fully understand, and abide by the company's Policies and Procedures.
8. Do not sell Leveluk Machines at a discounted price.
9. Run your distributorship in a legal and ethical manner.

Instructions on Applications

The Product Order Form and Distributor Agreement as well as other relevant forms and documents are available in Enagic Office and can also be accessed on our website www.enagicph.com/downloads.

General Instructions:

- Fill-out the Product Order Form and Distributor Agreement. Ensure that YOU and your SPONSOR have SIGNED the said Form/ Agreement before submitting the same to the Company for further processing.

Application Process:

- **STEP 1:** Send all Forms to goc.phl@enagic.com
*Please make sure your mail file is not too big
- **STEP 2:** You will receive confirmation email of your Registration ID Number



- **STEP 3:** Please forwards said email to marketing@enagic.ph together with payment confirmation (Deposit Slip, MOTO for credit card,). Please do not send any other form which you already sent to goc.phl@enagic.com

*If it is E-payment, please send an original documents to Enagic Office. You may attach the AWB (Tracking number of delivery) to us.

- **STEP 4:** Enagic Philippines will contact or send you email once we prepared your products ready to pick up or deliver.
- **Payments should be deposited to Enagic Philippines bank accounts.**
- **Below should be submitted to office once confirmed by the staff to process invoicing and releasing of machines:**
 - **Cash Deposit or Credit Card payment:**
 1. Original Application Forms and 2 (Gov't IDs)
 2. Original validated deposit slip, MOTO form or physical manual card for swiping

➤ **E-Payment:**

- 1. Original application form and E-Payment Form**
- 2. Original validated deposit slip, MOTO form or physical credit card for manual swiping for the DOWN PAYMENT.**
- 3. Photocopy of 2 Gov't IDs and 3 months latest proof of billings**
- 4. Post Dated Checks**

- Ensure to fill-up the form completely, especially the “Sponsor Information” section. Your sponsor’s name and distributor ID number should be specified.
- Make sure to specify which Machine is being purchased in the “Item Ordered” section.
- There can only be one name listed as the applicant, with only one signature on the Product Order Form and Distributor Agreement and one Tax Identification Number (TIN). If more than one name is listed, whether as husband and wife or otherwise, the application will NOT be processed.
- Please note that the Company requires two (2) valid government issued IDs as proof of identity.
- The “Shipping Details” section is to be filled out only when the buyer wants to ship the Machine to another address which must include the recipient’s name and contact number. The Machine shall be delivered only upon full payment.
- The Product Order Form and the Distributor Agreement must be duly signed by the applicant and his/her Sponsor in the portions designated on the forms.
- The TIN of the applicant, either as a Distributor or as a User, must be specified or must be VALID; without it, the application will not be processed.
- The Distributor must be able to provide an Official Receipt within seven to fifteen (7-15) days from date of receipt of commissions. Distributors shall be informed by email of the amount and date when the commissions have been remitted.
- All Distributors are personally responsible for paying applicable local and internal revenue taxes due to their earnings from commissions or any other earnings generated as a seller of Company products and services. The Company, as a withholding tax agent, is required by the BIR to withhold applicable tax on income payments to Distributors. The Distributors shall promptly provide any information, document and assistance which may be requested by the Company in order for it to comply with its responsibilities as such withholding agent

Purchasing thru One-Time Payment

One-Time Payment as a Distributor

Specific Information

- When filling out and submitting an application as a User, the Product Order Form and Distributor Agreement must be fully accomplished accordingly and duly signed.
- **Application FORM FOR MACHINE PURCHASE must be emailed directly by buyer (or sponsor) to goc.phl@enagic.com for registration.**

IMPORTANT: Follow the “Application Process” Step 1 to 4 on pages 5-6 under Instructions on Applications

- Payments should be deposited to Enagic Philippines bank accounts.
- Below should be submitted to office once confirmed by the staff to process invoicing and releasing of machines:
 - **Cash Deposit or Credit Card payment:**
 1. **Original Application Forms and 2 (Gov’t IDs)**
 2. **Original validated deposit slip, MOTO form or physical manual card for swiping**
- Distributor’s Banco De Oro (“BDO”) Account: For the payout of commissions, the Buyer who intends to be a Distributor must provide his **BDO account name and account number**. Should the Distributor fail to provide the said account details, he will be registered as a User. The information required herein must be complete in order that the application may be processed; otherwise, the application will be put on hold.

One-Time Payment as a User

- When filling out and submitting an application as a User, the Product Order Form and Distributor Agreement must be fully accomplished accordingly and duly signed.
- **Application FORM FOR MACHINE PURCHASE must be emailed directly by buyer (or sponsor) to goc.phl@enagic.com for registration.**

IMPORTANT: Follow the “Application Process” Step 1 to 4 on pages 5-6 under Instructions on Applications

- Payments should be deposited to Enagic Philippines bank accounts.
- Below should be submitted to office once confirmed by the staff to process invoicing and releasing of machines:

- **Cash Deposit or Credit Card payment:**
 1. **Original Application Forms and 2 (Gov't IDs)**
 2. **Original validated deposit slip, MOTO form or physical manual card for swiping**

One-Time Payment as a Business Entity

Specific Information

- If the applicant is a business entity, copies of the following papers must be submitted to the Company: (1) valid and current local business permit/licenses; (2) Securities and Exchange Commission (SEC) Certificate of Incorporation and Articles of Incorporation (for corporation); (3) SEC Certificate of Recording of Articles of Partnership and Articles of Partnership (for partnerships); or (4) Department of Trade and Industry (DTI) Registration (for single proprietorship).
- The ID requirement refers to two (2) valid government-issued IDs of the entity's President, Managing Partner/Partner-in-charge, or Proprietor, whichever is applicable.
- When filling out and submitting an application as a User, the Product Order Form and Distributor Agreement must be fully accomplished accordingly and duly signed.
- **Application FORM FOR MACHINE PURCHASE must be emailed directly by buyer (or sponsor) to goc.phl@enagic.com for registration.**

IMPORTANT: Follow the "Application Process" Step 1 to 4 on pages 5-6 under Instructions on Applications

- **Payments should be deposited to Enagic Philippines bank accounts.**
- **Below should be submitted to office once confirmed by the staff to process invoicing and releasing of machines:**
 - **Cash Deposit or Credit Card payment:**
 1. **Original Application Forms and 2 (Gov't IDs)**
 2. **Original validated deposit slip, MOTO form or physical manual card for swiping**

Purchasing with Enagic Payment Plan

Enagic allows its Buyers to pay their purchased Machines and other selected items specified in the E-Payment Chart Plan on installments thru the Enagic Payment Plan (“E-Payment Plan”). Generally, a Buyer shall be required to make a down payment prior to his acquisition of the Machine. Thereafter, installment payments must be made monthly until the Machine is paid in full.

The Product Order Form, Distributor Agreement and E-Payment Agreement must be duly accomplished and submitted. The Buyer must review and sign the E-Payment Agreement Terms and Conditions. The agreement is available at the Enagic Office and can also be accessed on our website www.enagicph.com/downloads.

Understanding the Enagic-Payment Application

- A person can only purchase one (1) Machine at a time through the E-Payment Plan. If a person wishes to purchase a second Machine on installment, he must wait until the first Machine has been paid in full. This rule shall also apply to other selected items specified in the E-Payment Chart Plan and to those who would like to become an Alternate Payor for someone else.
- The Applicant Information section must be filled-up. In cases where there is an Alternate Payor, both the Applicant Information and Alternate Payor Information sections must be filled-up.
 - **Application FORM FOR MACHINE & UKON PURCHASE must be emailed directly by buyer (or sponsor) to goc.phl@enagic.com for registration. For E8PA purchase please email to application-status@enagic.ph**

IMPORTANT: Follow the “Application Process” Step 1 to 4 on pages 5-6 under Instructions on Applications

- **Payments should be deposited to Enagic Philippines bank accounts.**
- **Below should be submitted to office once confirmed by the staff to process invoicing and releasing of machines:**
 - 1. Original application form and E-Payment Form**
 - 2. Original validated deposit slip, MOTO form or physical credit card for manual swiping for the DOWN PAYMENT.**
 - 3. Photocopy of 2 Gov’t IDs and 3 months latest proof of billings**
 - 4. Post Dated Checks**
- **Distributors (regardless of rank) are allowed to be an Alternate Payor for a maximum of three (3) accounts only.**
- The amount of the monthly payments based on the Enagic Payment Chart and the number of monthly payments that will be needed to pay the unit in full must be specified.

- Post-dated checks should be dated and deposited on every 20th of every month. If the 20th falls on a weekend or holiday, deposit dates will be on the next banking day.
- Enagic shall require the Buyer to submit three (3) latest proof of billings (e.g., electric, water, telephone and postpaid plan) bearing his name and address, clear copies of two (2) valid government issued IDs with signature and bank statement pertaining to his bank transactions for the last three (3) consecutive months.

Verification process will commence only once the documents are completely submitted to the Company.

E-Payment Plan Chart

The first payment shall include Deposit + VAT + Admin Fee of the chosen installment plan. The amounts herein are subject to change without prior notice.

Monthly payments table:

Model		6 months	10 months	16 months
Kangen 8 Php 246,400	SRP (VAT Inclusive)	246,400.00	246,400.00	246,400.00
	ADMIN FEE	2,400.00	4,000.00	6,400.00
	TOTAL PRICE	248,800.00	250,400.00	252,800.00
	DOWN PAYMENT			
	Deposit	35,200.00	35,200.00	35,200.00
	12% VAT	26,400.00	26,400.00	26,400.00
	Admin Fee	2,400.00	4,000.00	6,400.00
	Total Down Payment	64,000.00	65,600.00	68,000.00
	Remaining Balance	184,800.00	184,800.00	184,800.00
Monthly Amortization	30,800.00	18,480.00	11,550.00	
Model		6 months	10 months	16 months
SD501-PT Php 218,400	SRP (VAT Inclusive)	218,400.00	218,400.00	218,400.00
	ADMIN FEE	2,400.00	4,000.00	6,400.00
	TOTAL PRICE	220,800.00	222,400.00	224,800.00
	DOWN PAYMENT			
	Deposit	31,200.00	31,200.00	31,200.00
	12% VAT	23,400.00	23,400.00	23,400.00
	Admin Fee	2,400.00	4,000.00	6,400.00
	Total Down Payment	57,000.00	58,600.00	61,000.00
	Remaining Balance	163,800.00	163,800.00	163,800.00
Monthly Amortization	27,300.00	16,380.00	10,237.50	
Model		6 months	10 months	16 months
SD501 Php 201,600	SRP (VAT Inclusive)	201,600.00	201,600.00	201,600.00
	ADMIN FEE	2,400.00	4,000.00	6,400.00
	TOTAL PRICE	204,000.00	205,600.00	208,000.00
	DOWN PAYMENT			
	Deposit	28,800.00	28,800.00	28,800.00
	12% VAT	21,600.00	21,600.00	21,600.00
	Admin Fee	2,400.00	4,000.00	6,400.00
	Total Down Payment	52,800.00	54,400.00	56,800.00
	Remaining Balance	151,200.00	151,200.00	151,200.00
Monthly Amortization	25,200.00	15,120.00	9,450.00	
Model		6 months	10 months	16 months
ANESPA DX Php 140,000	SRP (VAT Inclusive)	140,000.00	140,000.00	140,000.00
	ADMIN FEE	2,400.00	4,000.00	6,400.00
	TOTAL PRICE	142,400.00	144,000.00	146,400.00
	DOWN PAYMENT			
	Deposit	20,000.00	20,000.00	20,000.00
	12% VAT	15,000.00	15,000.00	15,000.00
	Admin Fee	2,400.00	4,000.00	6,400.00
	Total Down Payment	37,400.00	39,000.00	41,400.00
	Remaining Balance	105,000.00	105,000.00	105,000.00
Monthly Amortization	17,500.00	10,500.00	6562.50	

Model		6 months	10 months	16 months	20 months	24 months
Leveluk JRIV Php168,000	SRP (VAT Inclusive)	168,000.00	168,000.00	168,000.00	168,000.00	168,000.00
	ADMIN FEE	1,200.00	2,400.00	3,200.00	4,000.00	4,800.00
	TOTAL PRICE	169,200.00	170,400.00	171,200.00	172,000.00	172,800.00
	DOWN PAYMENT					
	Deposit	12,000.00	12,000.00	12,000.00	12,000.00	12,000.00
	12% VAT	18,000.00	18,000.00	18,000.00	18,000.00	18,000.00
	Admin Fee	1,200.00	2,000.00	3,200.00	4,000.00	4,800.00
	Total Down Payment	31,200.00	32,000.00	33,200.00	34,000.00	34,800.00
	Remaining Balance	138,000.00	138,000.00	138,000.00	138,000.00	138,000.00
	Monthly Amortization	23,000.00	13,800.00	8,625.00	6,900.00	5,750.00

Model		3 months
UKON DD (TEA&SOAP) * Php 47,040	SRP (VAT Inclusive)	47,040.00
	ADMIN FEE	1,350.00
	TOTAL PRICE	48,390.00
	DOWN PAYMENT	
	Deposit	15,000.00
	12% VAT	5,040.00
	Admin Fee	1,350.00
	Total Down Payment	21,390.00
	Remaining Balance	27,000.00
	Monthly Amortization	9,000.00

Model		10 months
UKON SIGMA (TEA&SOAP) * Php 123,200	SRP (VAT Inclusive)	123,000.00
	ADMIN FEE	4,500.00
	TOTAL PRICE	127,700.00
	DOWN PAYMENT	
	Deposit	37,000.00
	12% VAT	13,200.00
	Admin Fee	4,500.00
	Total Down Payment	54,700.00
	Remaining Balance	73,000.00
	Monthly Amortization	7,300.00

Model		6 months	12 months
Emgarde Php 94,080	SRP (VAT Inclusive)	94,080.00	94,080.00
	ADMIN FEE	2,400.00	4,800.00
	TOTAL PRICE	96,480.00	98,880.00
	DOWN PAYMENT		
	Deposit	34,841.00	32,698.00
	12% VAT	4,181.00	3,924.00
	Admin Fee	2,400.00	4,800.00
	Total Down Payment	41,422.00	41,422.00
	Remaining Balance	55,058.00	57,458.00
	Monthly Amortization	9,176.33	4,788.17

E-Payment Policies & Procedures

● APPLICATION REQUIREMENTS

- The Application Form and E-Payment Agreement must be fully filled-up and signed by the Distributor and his/her Sponsor.
- In case the applicant would like to avail of the E-Payment Plan, the E-Payment Agreement form must likewise be accomplished and duly signed by the New Distributor and his/her sponsor.
- **Application FORM FOR MACHINE & UKON PURCHASE must be emailed directly by buyer (or sponsor) to goc.phl@enagic.com for registration. For E8PA purchase application please email to ukon-phl@enagic.ph and or application-status@enagic.ph**

IMPORTANT: Follow the “Application Process” Step 1 to 4 on pages 5-6 under Instructions on Applications

- Payments should be deposited to Enagic Philippines bank accounts.
- Below should be submitted to office once confirmed by the staff to process invoicing and releasing of machines:
 1. Original application form and E-Payment Form
 2. Original validated deposit slip, MOTO form or physical credit card for manual swiping for the DOWN PAYMENT.
 3. Photocopy of 2 Gov't IDs and 3 months latest proof of billings
 4. Post-Dated Checks
 5. **Cash Payment Agreement Contract (if mode of monthly payment is in cash)**
- **Two (2) valid Government-issued IDs with signatures (should be clear copy), bring the original for verification.**
- For three (3) current proof of billings, such as: telephone, postpaid plan, water utility and electric utility.
- Down payment to be paid in cash, credit card or check. **Cash MUST be deposited in Enagic's bank account and the corresponding deposit slip (original) must be submitted to Enagic.** Credit card payments are also accepted. For check payments, the check must be cleared first before the unit will be released.
- **Post-dated checks should be dated and deposited on every 20th of every month. If the 20th falls on a weekend or holiday, deposit dates will be on the next banking day.**

● **TERMS & CONDITIONS**

- Enagic reserves the right to accept or decline any application without the obligation to give any reason/s therefor.
- Enagic has the right to determine the amount of Admin Fee, and such may be subject to change without prior notice.
- Enagic will conduct verification calls after receiving the complete application form.
- *If the Buyer fails to pay on or before the due date, a five percent (5%) penalty fee based on the monthly due shall be applied on top of the monthly amortization for every delayed payment.
- *Enagic reserves the right to offset/deduct any unpaid amount/amortization from the Buyer's commissions/receivables.
- The penalty fee may not be waived. Any request on this matter will not be entertained.
- For unpaid obligations and after sales transactions of those paying in cash, the Buyer must pay directly to Enagic through the latter's bank account:
BDO Unibank Inc.: Enagic Philippines, Inc./Account No. 8230028457
- If the Buyer opts to pay for the monthly installments through his duly approved credit card, an additional 4.5% charge shall be applied on top of the billed amount. In addition, only straight payments shall be allowed.
- This mode of payment shall be allowed for the purchase of only one (1) Machine at a time.
- Direct Sponsor and Direct 6A of the Applicant shall serve as the representative of the entire eight (8) points up line.
- Enagic reserves the right to deduct from 6A and above Distributor's bonuses and incentives based on their collection rate without prior notice. (*Please refer to the COLLECTION RATE & BONUSES CHART*)
- **If buyer becomes delinquent and unable to pay the installment payments as they fall due, ENAGIC reserves the right to appoint a 3rd party Collection Agency for the outsourcing of EXTRA-JUDICIAL collection of delinquent accounts with twenty five percent (25%) collection fee and late payment fee of PHP 5,000.00.**
- **Once delinquent account is fully settled under EXTRA-JUDICIAL collection, ENAGIC will collect back from the commissions the twenty five percent (25%) collection fee to all distributors within 8 points system.**

Sample of Collect Back									
Outstanding Bal	95,700.00								
Collection Fee 25%	23,925.00								
8 Points System									
Distirbutor# 1	Distirbutor# 2	Distirbutor# 3	Distirbutor# 4	Distirbutor# 5	Distirbutor# 6	Distirbutor# 7	Distirbutor# 8	Tota Commission	
9,120.00		6,720.00	3,360.00	13,440.00	3,360.00			36,000.00	
Sharing of Collection fee of 25%	6,061.00		4,466.00	2,233.00	8,932.00	2,233.00			23,925.00

- If the sponsor is availing of the E-Payment or a TOKUREI as defined below, they need to sign the E-payment Guarantee Form.
- The Admin Fee cannot be adjusted or refunded even if the amounts due under the E-payment are fully paid prior to their due dates.
- The Applicant may only submit Change of Name & Transfer of Distributorships once the account is fully settled.
- For those Distributors who paid through post-dated checks, Enagic shall not allow any request to hold or pull out the same.
- The Applicant should be 18 years old and above.
- If Distributor request to extend the period of installment due delinquency, extension fee of PHP5,000.00 will be charge for maximum of 5 months. Terms and conditions will apply and will be subject for approval.

Other Payment Methods

Mail Order/Telephone Order

When filling out an application, a new User and/or Distributor needs to completely fill up and submit the Product Order Form, Distributor Agreement and Mail Order/Telephone Order Form (MOTO Form).

The Product Order Form and Distributor Agreement Form as well as all other forms are available in the Enagic Office and can also be accessed on our website www.enagicph.com/downloads.

Specific Information

- The Product Order Form, Distributor Agreement Form and the MOTO Form must be signed by the applicant in the portions specified therein to ensure full understanding of the policies.

Understanding the Mail Order/Telephone Order Application

- When filling out and submitting an application as a User, the Product Order Form and Distributor Agreement must be fully accomplished accordingly and duly signed.
- **Application FORM FOR MACHINE PURCHASE must be emailed directly by buyer (or sponsor) to goc.phl@enagic.com for registration.**

IMPORTANT: Follow the "Application Process" Step 1 to 4 on pages 5-6 under Instructions on Applications

- Enagic shall require the Buyer to submit a clear copy of his credit card (front only)
- Mail Order/Telephone Order application shall accept any VISA or MASTERCARD credit cards for STRAIGHT PAYMENT only. However, BDO and METROBANK credit card holders shall have the option to pay in either 3-, 12- or 24-months installment with 0% installment rate with NO down payment required.
- DEBIT cards are not accepted when using the Mail Order/ Telephone Order payment.
- Those paying on behalf of a Distributor shall also be required to fill up the Alternate Payor Information Form together with MOTO Form.
- Unless otherwise provided, no refunds shall be entertained under this method, including interest charges, in case the Distributor decides to cancel the purchase.

Credit Card

Understanding the Credit Card Payment Application

- When filling out and submitting an application as a User, the Product Order Form and Distributor Agreement must be fully accomplished accordingly and duly signed.
- **Application FORM FOR MACHINE PURCHASE must be emailed directly by buyer (or sponsor) to goc.phl@enagic.com for registration.**

IMPORTANT: Follow the “Application Process” Step 1 to 4 on pages 5-6 under Instructions on Applications

- **Payments should be deposited to Enagic Philippines bank accounts.**
- **Below should be submitted to office once confirmed by the staff to process invoicing and releasing of machines:**
 - **Credit Card payment:**
 1. Original Application Forms and 2 (Gov’t IDs)
 2. Physical Card for manual swiping.

The Buyer shall be required to submit a clear copy of his/her credit card (front only).

- Credit Card application shall accept any VISA and MASTERCARD credit card for STRAIGHT PAYMENT only.
- The applicable/current Credit Limit of the card should be more than the cost of the Machine.
- The Credit Card holder shall fill up the MOTO form in order that the charging of either the straight or installment payment methods can be processed.
- Unless otherwise provided, no refund shall be entertained under this method, including interest charges, in case the Distributor decides to cancel the purchase.

Those paying on behalf of a Distributor, shall also be required to fill up the Alternate Payor Information Form together with MOTO Form.

It is understood that Enagic can no longer refund the interest fee which was already charged by the bank.

The signature portion of the Credit Card must be duly signed.

Credit Card Installment Plan

Understanding the Credit Card Installment Plan Application

- When filling out and submitting an application as a User, the Product Order Form and Distributor Agreement must be fully accomplished accordingly and duly signed.
- **Application FORM FOR MACHINE PURCHASE must be emailed directly by buyer (or sponsor) to goc.phl@enagic.com for registration.**

IMPORTANT: Follow the “Application Process” Step 1 to 4 on pages 5-6 under Instructions on Applications

- **Payments should be deposited to Enagic Philippines bank accounts.**
- **Below should be submitted to office once confirmed by the staff to process invoicing and**

releasing of machines:

➤ Credit Card payment:

1. Original Application Forms and 2 (Gov't IDs)
2. Physical Card for manual swiping.

- The Buyer shall be required to submit a clear copy of his/her credit card (front only).
- Credit Card Installment Plan application shall accept any VISA or MASTERCARD credit cards for **INSTALLMENT PAYMENT subject to the applicable interest and other charges.** However, METROBANK, BDO and BPI credit card holders shall have an option to pay either 3-, 12- or 24-months installment with 0% installment rate with NO down payment required
- The applicable/current Credit Limit of the card should be more than the cost of Machine. The full amount due will be charged and shall be deferred depending on the number of installments preferred/chosen by the Buyer.
- Credit card holders must fill up the MOTO form in order to process the charging of payment.
- Mixed payment with credit card installment shall be computed according to credit card installment rates.
- Those paying on behalf of a Distributor shall also be required to fill up the Alternate Payor Information Form together with the MOTO Form.
- It is understood that **Enagic can no longer refund the interest fee which was already charged by the bank.**
- The signature portion of the Credit Card must be duly signed.

Machine Sales Order via Email

A new User and Distributor shall be required to completely fill up and submit the Product Order Form and Distributor Agreement Form via email for Distributors who are located in provincial areas and/or in another country. Note, however, that the Machines are only being sold by Enagic in the Philippines.

Understanding the Machine Sales Order via Email

- The Buyer shall be required to submit a clear copy of Product Order Form and Distributor Agreement via email. However, for provincial area purchases, there is still a need to submit and send the original application form and deposit slip to the Manila office.
- **Application FORM FOR MACHINE PURCHASE must be emailed directly by buyer (or sponsor) to goc.phl@enagic.com for registration.**

IMPORTANT: Follow the "Application Process" Step 1 to 4 on pages 5-6 under Instructions on Applications

- Credit card holder should fill up the MOTO form in order to process the charging of payment.
- The Company shall reply to all duly received complete filled-up applications (and with complete requirements) within two (2) working days, regardless of the chosen payment method.

All Machine sales order via email shall be closed at 6:00pm every day. Application forms received after 6:00pm will be processed on the following business day.

Signing Up as a Tokurei (Good Samaritan) Distributor

A Tokurei (Good Samaritan) is someone who may be unable to purchase Machines but would still like to be one of the Distributors of the Company. That person will primarily function as a “partial” Distributor such that even if he will be able to sell the Machines, he will only receive partial commissions.

Understanding the Tokurei System

To sign up as a Tokurei, a person must submit the application forms required (i.e., Product Order Form and Distributor Agreement Form, Tokurei Application Form) and two (2) copies of valid Government ID's), along with the application of someone who is purchasing the Machine either by full payment or thru the E-Payment Plan. The Tokurei shall sponsor the Buyer, and therefore will start with one sale, or one 1A leg.

- Enagic requires Tokurei Distributors to purchase “Tokurei Starter Kit” for P1,200.00 (+12% withholding tax). The kit includes one (1) pH Tester, Distributor Handbook, Catalogues and latest E-friends)
- When signing up as a Tokurei, one needs to select which Machine he/she intends to sponsor.
- A Tokurei will not receive the Machine until enough commissions have been accumulated to fully cover the cost of the Machine.
- A person using the Tokurei plan shall receive a basic commission minus the amount withheld in the event of a Machine sale and Machine has been paid for in full.
- As a Tokurei, every time a sale is made within the 8-point structure, a part of the commission shall be allocated to the Tokurei's selected Machine. For example, if a Tokurei is selling an SD501 Machine which is to be paid in full, the normal commission therein minus the SP bonus would be P9,600.00, then the Tokurei shall receive P5,600.00. The P4,000.00 difference shall be saved up to cover the Tokurei's Machine.
- A Tokurei is allowed to upgrade but not to downgrade the Machine initially chosen. The basis to determine whether it is for upgrading/downgrading shall be the price of the Machines chosen.
- Special Point “SP” will not be counted for the Distributor using the Tokurei plan.
- If a Distributor already has an existing Tokurei account, he cannot sign up as a Tokurei for a second or third account.
- Customers who are under the Tokurei program are not allowed to sign as an Alternate Payor for any payments for someone else's Machine.
- The option to sign up as a Tokurei is only allowed for individuals signing up with Enagic for the first time.
- Distributors signing up as a business entity shall not be allowed to register as a Tokurei.
- If a Distributor's downline is a Tokurei, the Distributor concerned will not receive any commissions until after the Tokurei status has been cancelled.
- Excess accumulated commissions are deemed forfeited – they cannot be paid in cash, check or exchanged with accessories.
- In case the Tokurei status is for cancellation, such should be stated in the email. In this regard, the Tokurei ID number and the name of the Tokurei distributor must be provided.

- After the cancellation of Tokurei status, the Distributor needs to have at least one (1) direct sale of a Machine (which can be a Member's Price Machine) in order to receive a full commission (SP), otherwise he will only receive a basic commission.
- Tokurei distributors shall be asked to provide an Official Receipt upon the receipt of their commissions, whether it be basic or special. They are required to send the Official Receipts within 7-15 days from date of receipt of commission. The Company's Accounting Department shall be sending out an email information on the said commission releases.
- All Distributors are personally responsible for paying local and internal revenue taxes due to their earnings from commissions or any other earnings generated as a seller of Company products and services. The Company, as a withholding tax agent, is required by BIR to withhold applicable tax on income payments to distributors. The distributors shall promptly provide any requested information, document and assistance which may be requested by the Company in order to comply with its responsibilities as the withholding agent.
- For the respective prices of the Machines, please refer to the table below (Note: Prices are subject to change even without prior notice):
- **Application FORM FOR MACHINE PURCHASE must be emailed directly by buyer (or sponsor) to goc.phl@enagic.com for registration.**
- **Machine application form registration status can be checked in Enagic Philippines website.**
- **Marketing team will contact for the machine pick-up delivery details within 48 hours.**

Model	Price	Accumulated Commission
SD501	P201,600.00	P4,000.00
SD501-PT	P218,400.00	P4,000.00
JRIV	P168,000.00	P4,000.00
Super 501	P291,200.00	P8,000.00
Anespa	P140,000.00	P4,000.00
Super 501 (E8PA Card Holder)	P250,880.00	P8,000.00
Anespa (E8PA Card Holder)	P112,000.00	P4,000.00

Processing of Orders

- Enagic Office is open from Mondays to Sunday from 10am to 7pm.
- Unless otherwise stated, the failure to comply with all the application requirements as a User/Distributor will result in delay in the processing of the application. The same will not be processed until all the requirements have been complied with.
- The name to be written on the application forms must match the name written on the valid IDs. The use of **nickname/s will not be allowed.**
- If the applicant's name and the name on the bank account or credit card which will be used as a mode of payment for the Machine are not the same, the Alternate Payor section must be filled out.
- If a Machine is being purchased under the company's name but is to be paid for by another's personal credit card or bank account, the Alternate Payor section must also be filled out.
- With regard to the section which provides "*Register the applicant as ()*" in the Product Order Form and Distributor Agreement, the Distributor-Sponsor must state what line the sale will be under. For example, if the sponsor has 7 prior sales, he needs to write number "2" to signify that the new sale will create a 2A leg for them. If the sponsor has 14 prior sales, he can choose to put the new sale on either 2A or 3A leg.
- A Tax Identification Number (TIN) and BDO account shall also be required in order for the application to be processed. If either of the two is not provided, the Applicant will be processed as a User until the said requirements have been fully complied with.
- The Distributor must notify the Company of any changes in relation to the details that he has previously provided, like his/her address and telephone number.
- **Application FORM FOR MACHINE PURCHASE must be emailed directly by buyer (or sponsor) to goc.phl@enagic.com for registration.**
- **Machine application form registration status can be checked in Enagic Philippines website.**
- **Marketing team will contact for the machine pick-up/ delivery details within 48 hours.**

Order of Accessories

- Sold accessories cannot be refunded or returned.
- The purchase of accessories cannot be made through telephone. However, the same may be made via e-mail. The buyer must send the supply order form via email and enumerate therein the accessories he/she wants to purchase. Upon receiving the order form from the Buyer, the Enagic staff shall calculate the entire price of the accessories together with courier fees and send back the order form to the Buyer who may then deposit his/her payment to Enagic's bank account specified in this Handbook.
- Purchase can also be made thru our webstore/ online store, <https://store.enagic.com/ph/home/>.

You may refer to "Enagic PH Webstore User Guide" just go to our website <https://www.enagicph.com/> >> Download tab >> User Manual.

- All duly accomplished forms, with a copy of the deposit slip, received by Enagic before 6pm shall be processed within the day. Otherwise, the same will be processed on the following business day.
- Similarly, all orders of accessories through email shall be accommodated until 6pm. The orders received after 6pm will be processed on the following business day.
- All orders for accessories with NO proof of payment shall not be processed.
- **NO CASH POLICY.**

Other Information

- 6A's who are direct sponsors of a sale shall not be allowed to fill out the 6A support section of the application.
- **Change of Name:** The name change form must be submitted through registered mail, a reputable courier, or e-mail. The change of name with regard to the ownership of Machine shall only be allowed between first degree relatives. In the event of financing, the financing must first be completed in order to do a name change. Also, a name change cannot be applied to a Tokurei.
 - Normal transfer of account to other customer/distributors fee is **P2,000.00**.
 - Deceased distributor but transfer to family member for the purpose claiming of commission fee is **Php 1,000.00**.
 - Transfer of distributorship to family member fee is **Php 500.00**.
 - Deceased distributor but transfer to family member for Enagic to collect the outstanding balance is **free of charge**.

- To do an address change, you must simply send the change of address form.
- Enagic shall not be involved in Distributor disputes. All disputes must be discussed and handled through the Distributor's 6A level. If the issue in question involves a Distributor's 6A level, a person with a higher level must be contacted. 6A level and above Distributors should call the Company in the event that they are unable to resolve their disputes.
- Machines may be upgraded but never downgraded. Distributors are allowed to upgrade their Machine within thirty (30) days from purchase. However, the Machine to be upgraded must not have any scratches or dirt and must not yet have been installed by the Distributor or other persons. The Machine upgrade has an Admin Fee of Php3,000.00.
- The Regional Change Admin Fee is Php2,000.00.
- Should an account of a Distributor be cancelled, he/she has to wait for a period of six (6) months from date of cancellation before he/she may apply again as a Distributor.
- For other relevant information and announcements from the Company, please visit Enagic Philippines Facebook Page.

Rules for Self-Purchase Enroller Sales (Revised)

Enroller sales work for distributors/customers making multiple self-purchases.

The rules that HQ have set are as follows,

1. If a distributor/user is purchasing a second product directly under their direct sponsor, **they can only purchase using the same enroller they used for the first purchase.**

2. If a distributor/user is purchasing a second product directly under themselves, **they can only purchase using themselves as the enroller and sponsor.**

Until now, we were allowing distributors/users to purchase multiple products under their downline as long as they were in their 6A group, but from now,

3. If a distributor/user decides to purchase a second product, **it can only be purchased directly under their direct sponsor or directly under themselves.** Distributors/users will not be allowed to purchase their second product under their downlines even if it is in their 6A group.

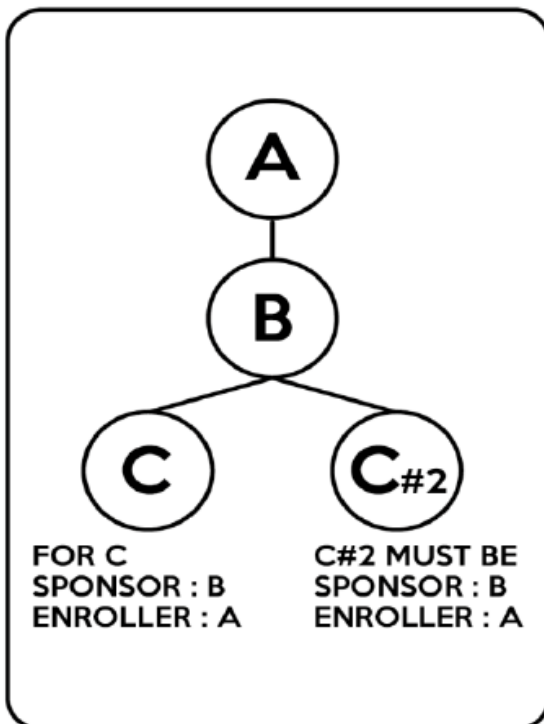

OR

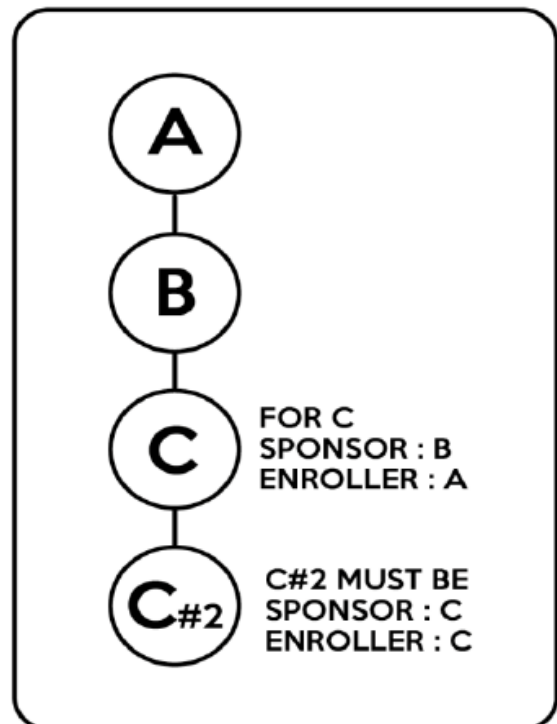

Types of Enagic Forms

- **Alternate Payor Form:** This form is used if someone is paying for the Machine on behalf of another.
- **Cancellation of Distributorship Form:** This form is used for those Distributors who would like to cancel their distributorship.
- **Change of Name/Address Form:** This form is used when a Distributor wants to change the name of the registered Distributor. The change of name is applicable to relatives of the first civil degree only. Also, if the distributor transfers from one place to another, the new address and contact number should be updated. The registration of the changes herein has a corresponding fee of P2,000.00.
- **Commission Chart:** This chart shows the commissions for all Machines.
- **Commission Research Form:** This is used when a Distributor wants to inquire about his previous or upcoming commissions.
- **Consignment Form:** This is for 6A and above Distributors who wish to consign their Machines.
- **Enagic Payment Agreement Form:** This is submitted together with Product Order Form and Distributor Agreement in order to purchase a Machine through in-house financing.
- **Extension of Monthly Payment Form:** This form is used to extend the period of monthly installment payments with an extension fee of P5,000.00.
- **Genealogy Request Form:** This form is used when a Distributor wants to request a genealogy – a list of all his sales.
- **Installment Plan Chart:** This chart shows the installment plan of Machines for E-Payment and Credit Card Installment Plan.
- **Itinerary Form**
- **Mail Order/Telephone Order Form:** This form is used to process the charging of payment. The credit card holder should fill up Mail Order/Telephone Order form (MOTO form); this is in case the credit card holder is not able to be physically present or out of town.
- **Memorandum of Agreement:** This form should be signed by Distributors who cannot provide a BDO Account and will be considered as a USER ONLY. Upon signing this form, the Distributor can receive commission through check or a deposit to his existing bank account provided that the next commission must be through BDO Account.
- **Offset Request Form:** This form is used when a Distributor wants to offset his commissions with the monthly payments for his Machine.

- **Payment Inquiry Form:** This form is to be submitted when a Distributor wants to inquire about his monthly balance and payment as well as when a Distributor wants to pay his monthly balance in the Enagic Office.
- **Product Order Form & Distributor Agreement:** These forms are generally used to purchase any kind of Machine.
- **Product Pricelist Chart:** This chart shows the price list of all the Machines.
- **Regional Change Form:** This form is used when a Distributor wants to transfer from one country to another. Both current and new regional sales manager should sign the form. Regional change has a corresponding fee of Php 2,000.00.
- **Room Booking Reservation Form**
- **Special Registration Agreement (Tokurei Form):** This form is used when the applicant is someone who may be unable to purchase the Machine but would still like to be one of the Distributors of the Company. This form is submitted together with Product Order Form & Distributor Agreement in order to become a Tokurei Distributor.
- **Supply Order Form:** This form is used for the purchase of Enagic accessories.
- **Technician Form**
- **Tokurei Status Cancellation Form:** This form is used when a Distributor wants to cancel his Tokurei status.
- **Upgrade Unit Form:** This form is used when someone wants to upgrade his Machine within the allowable period.

General E-Mail Information

Particular	E-mail
Order Information & Forms	application-status@enagic.ph
Ukon Application	ukon-phl@enagic.ph
Collections	collections@enagic.ph
Commissions	commissions@enagic.ph
Compliance	compliance@enagic.ph
Service / Service inquiry / Online service inquiry	service-manila@enagic.ph
Events and Seminar	marketing@enagic.ph

Bank Details

Please refer to the Company's bank account details below for remittances, bank or telegraphic transfers of payments for machines and accessories.

Bank/ Branch Name	BDO Unibank Inc./ Bonifacio Global City- The Infinity Tower Branch
Beneficiary Account Name	Enagic Philippines, Inc.
Account Number	8230028457
Swift Code	BNORPHMM
Branch Code	823
Bank Address	Unit 103, The Infinity Tower, 26th Street, Bonifacio Global City, Fort Bonifacio, Taguig City

Bank/ Branch Name	RCBC Savings Bank Corporate Center Branch
Beneficiary Account Name	Enagic Philippines, Inc.
Account Number	7590061314
Swift Code	RCSAPHM1
Branch Code	6174
Bank Address	G/F A.T. Yuchengco Centre 25 th & 26 th Streets, Bonifacio Global City, Fort Bonifacio, Taguig City

Bank/ Branch Name	Metropolitan Bank and Trust Company / Fort South of Market
Beneficiary Account Name	Enagic Philippines, Inc.
Account Number	3197319523029 (Peso Current Account)
Swift Code	MBTCPHMM
Branch Code	'319
Bank Address	Ground Floor Twin Tower Building. Corner 11 th Avenue and 26 th Street, South of Market

Shipping Information

- The Distributor shall be responsible for all shipping fees and import tariff or tax (if any) in relation to his/her orders. These are non-refundable under any circumstance.
- The Machine shall only be shipped after the payment is cleared and if the stock is available.
- All applications with incomplete documents cannot be shipped regardless of the payment method used.
- All orders for accessories with NO proof of payment shall not be shipped.
- Shipping fee charges:

LeveLuk SD501, SD501-PT, JRIV, ANESPA, K8, and SUPER501.

	Shipping days (Regular/Normal days)	Luzon	Visayas	Mindanao
AP Cargo	3-5 business days	N/A	Collect	Collect
LBC	3-5 business days	Php 2,510.00	Php 2,510.00	Php 2,510.00
JRS	3-5 business days	Php 2,510.00	Php 2,510.00	Php 2,510.00

Ukon DD & SIGMA

	Shipping days (Regular/Normal days)	Luzon	Visayas	Mindanao
LBC & JRS				
Ukon DD	3-5 business days	Php 600.00	Php 650.00	Php 650.00
Ukon Sigma	3-5 business days	Php 1,100.00	Php 1,250.00	Php 1,250.00

- For accessories, the shipping charges shall depend on the quantity of orders made.

In order for the User/Distributor to track his ordered goods, **Enagic will provide him/her with the tracking number/airway bill covering the goods thru email or sms**

Seminar Room Booking

For seminar room booking, please email and contact our marketing staff at marketing@enagic.ph. The distributor must accomplish a "seminar room booking form" to request. The form is also uploaded in the website (<https://www.enagicph.com/downloads>).

All reservations must be done by submitting the said form at least one (1) week before the seminar date. Please take note that there will be NO schedule of seminars on Public Holidays.

Starting September 1, 2024, our Seminar Room will no longer accommodate EXCLUSIVE EVENT from distributors, it must be OPEN to everyone.

General Commission Information and SP

- Please have your distributor ID number ready when calling to make any inquiries.
- Please wait for at least ten (10) business days before calling to ask any missing commission checks.
- The inquiries on commissions may also be made via e-mail to commissions@enagic.ph. Please wait for forty-eight (48) business hours or two (2) working days for the reply.
- To avoid delays, please ensure that all customer information/ documentations are submitted, i.e., front copy of BDO ATM bank statement or bank details with Sponsor’s signature and application form.
- Memorandum of Agreement - This document is to be entered into by Enagic and its Distributors. If the Distributor cannot provide a copy and/or do not want to open BDO account, Enagic can issue the first commission by check or through other bank accounts proposed by Distributor but he needs to provide a BDO account for succeeding commissions.
- “SP” status - If there are direct sales made within three (3) months, the Distributor will be qualified to receive regular commissions, 6A educational allowances and/ or incentives.
- “D1” status - If there are no direct sale made within four to six (4-6) months, the Distributor will be qualified to receive basic commissions, 6A educational allowances and/or incentives.
- “D0” status - If there are no direct sale made within seven to twelve (7-12) months, the Distributor is only allowed to receive fifty percent (50%) of 8-Point commissions, 6A educational allowances and/ or incentives.
- “FAO” status - If there are no direct sales made for more than one (1) year, the Distributor will not be qualified to receive any commission, 6A educational allowance and/or incentive.
- As for the **FAO transfer**, the rules will not change. Only distributor who have not been active for two (2) years will be able to apply for the FAO transfer.

<i>Distributor Sales Status (SD501 Example)</i>		<i>Amount</i>
SP (with Special Point)	Additional bonus payment whenever a direct sale is made within 3 months	P12,000.00
D1 (Normal Status)	A direct sale has been made within 4-6 months	P 9,600.00
D0 (Partial Status)	A direct sale has been made for over 7-12 months	P 4,800.00
FAO	No direct sale for more than 1 year.	P 0.00

<u>Filter Commission</u>	<u>Regular Price</u>	<u>SalePrice</u>
HighGradeFilter	Php300/Point	Php150/Point
K8 Filter	Php300/Point	Php150/Point
FC1	Php393/Point	Php225/Point
Anespa External Filter	Php300/point	Php150/Point
Anespa Ceramic Filter	Php300/Point	Php150/Point

*Filter commissions shall be issued once the accumulated amount reaches P5,000.00 or more.

Special Points (SP)

SP (Special Points) are additional bonus payments that are issued whenever direct sales are made by a Distributor (except for Tokurei distributors). Tokurei distributors will be qualified to receive SP when a direct sale is made after its Tokurei status has been cancelled. The SP lasts for ninety (90) days, and will discontinue automatically unless another direct sale is made. If a direct sale is made while still in the SP period, the end date of the SP period will be re-adjusted to three months from the date the direct sale order is processed. If a sale was not made and the SP period stopped, it can be resumed at any time by simply making a direct sale. SP is paid on all sales within 8 points during the bonus period. The payments are multiplied by rank. For example, if a person is a 3A and sells the SD501, they will receive Php7,200.

SP Bonus per Machine

<u>K8</u>	<u>Php 3, 000</u>
<u>SD501</u>	<u>Php 2, 400</u>
<u>DXII</u>	<u>Php 1, 800</u>
<u>JRIV</u>	<u>Php 1, 610</u>
<u>Super501</u>	<u>Php 3, 000</u>
<u>Anespa</u>	<u>Php 1, 200</u>
<u>Super501 (E8PA)</u>	<u>Php 2, 240</u>
<u>Anespa (E8PA)</u>	<u>Php 1, 000</u>

Please note that Commissions and Bonuses/Other Income are inclusive of all applicable local taxes e.g. value-added tax, expanded withholding tax and percentage tax.

Commission Payout Schedule

Description	Received Date	Released Date
Bonus (Monthly and Quarterly)	-	Every 25th of the month
Cancelled Tokurei	-	7 Working days after Cancelled in Enagic System
Filter Commissions	Need to accumulate to Php5,000**	Every 15 th and 30 th of the month**
Pay off Commissions Batch 1	Payment every 1st - 20th of the month	10th of the following month
Pay off Commissions Batch 2	payment every 21st - 31st of the month	25th of the following month
Sales Date (8 point / Educational)	DAILY	7 - 10 working days after registration (with complete documents)
Submit / Update Official Receipt (OR) and Joint Venture (JV)	DAILY	7 - 10 working days upon Submission/update
Submit BDO Accounts	DAILY	7 - 10 working days upon Submission/update
Ukon Commission	Need to accumulate Php10,000	Every 25 th of the month
Updated from Consignment / Past Due / Collection	-	7-10 working days once updated
Updated from Marketing (Documents OK)	-	7-10 working days upon compliance

Commission Procedures

1. Commissions will be processed after the registration date of the sale.
2. Processing will take seven (7) to ten (10) working days before payout.
3. Commissions are credited through any BDO Account, except for cash cards.
4. **For Filter commissions, it will only be processed once the Distributor has accumulated P5,000.00 and will only be released every 15th and 30th of the month. ****

Commission Requirements

1. The application must be accompanied with complete documents and payments.
2. The Sponsor must have an Official Receipt as mandated by BIR.
3. The Sponsor must have previously issued Official Receipts for his transactions with Enagic, whenever necessary.
4. The Sponsor must have updated payments in E-Payment.
5. The Sponsor must have a BDO Account, any account except for cash cards.
6. The Sponsor must have no pending issues with the Collection Department.
7. The Sponsor must have no pending issue/s with his consignments.

Consignment Process

All Consignment request must be sent via email. No over-the-counter request will be accepted and processed.

Cut-off for accepting consignment request (via email) is until 3PM.

Releasing of approved consigned machine will be the next working day starting at 12 noon.

1.) All consignment request **must be sent via email at consignment@enagic.ph**. Over the counter requests will not be entertained.

Email request must indicate the following information:

1. ID Number & Distributor Name
2. Units to be consigned
3. Quantity of units to be consigned

2.) Consignment status of the requesting distributor will be checked, such as overdue consignment, number of existing consignment and sales under their account. All Information and requests will be forwarded to the Branch Manager for approval.

3.) An email reply will be sent within the day to inform the status of request and corresponding information such as due date and release/pick up date of consigned machines will also be indicated. If not, please resend your email at consignment@enagic.ph

Note:

- All requests sent after 3PM will fall to the next cutoff which is the next working day. As well as an email reply will be sent to the next working day regardless of the status.

Consignment Rules and Regulations

1. 6A Distributors are only allowed to consign a maximum of three (3) units regardless how many 6A ID numbers they have. This is to lessen consignment units after 2015.
2. 6A Distributors who are relatives up to first civil degree can only together consign up to three (3) units.
3. Consignments are applicable to 6A Distributors only.
4. Consignments are subject to stock availability.
5. Consignments that are damaged will be charged to Distributor. A minimum charge of P560.00 for the replacement of the damaged box/packaging will be applied.
6. Consignments are not allowed two (2) days before the end of the month.

7. The Distributors are responsible for all related shipping fees and taxes which are non-refundable under any circumstance.
8. The Distributors shall submit all purchase orders and either pay the full amount to Enagic from the contract date or settle through any of the methods below within one (1) month from the purchase.
 - ✓ Pay the full amount.
 - ✓ Return the Machine in an unused and sealed condition. If the seal was tampered, the Machine will be considered as sold.
 - ✓ Release the Machine in a brand-new condition to other Distributors upon the request of the Company.
9. If the Distributor defaults in any payment or settlement on due date (30 days from consignment date), Enagic reserves the right to terminate the commissions, and to recall the Machines as long as they are still in a marketable condition.
- 10. Failure to liquidate after sixty (60) days, only full payment in cash (Deposit, check) or credit card (single or installment) is allowed. Commission (bonus) 100% deduction if you cannot sell by above mentioned payment method.**
- 11. Failure to liquidate after ninety (90 days), it is considered delinquent and shall be endorsed to the third (3rd) party collection agency for debt recovery. Those endorsed or turned over to the AGENCY, can no longer be assisted by ENAGIC in preventing this extra-judicial collection to take place. To compensate the cost of debt recovery, Enagic reserves the right to collect the 25% collection fee from the consignee's commission/s.**
12. The Company reserves the right to ask the Distributor for an explanation and to determine the status of the Machine at any time.

Commission Offset for Consignments

Terms and Conditions:

1. Consigned Machines should be fully paid or liquidated within thirty (30) days from consignment date. Failure to comply will lead to automatic commission to be put on hold.
2. As stated under Consignment Rules and Regulations, 100% commissions may be put on hold or offset as payment if the Distributor fails to return the consigned units or to settle on due date.
 - a. 100% will be put on hold if not returned or liquidated after thirty (30) days.
 - b. 100% will be offset as payment to the unreturned or unliquidated after sixty (60) days.
3. The commission amount put on hold shall be used as down payment for the registration of overdue consigned Machines. The machines will be registered under Consignee's Name and sponsored by Consignee's account wherein he can get the full commissions (8-point and Educational Allowance).
4. Pay off Commissions shall be continuously used to pay off the Distributor's remaining consigned machines until all consigned machines are fully paid for/settled.
5. The commissions will be released after all consigned machines are fully paid.
6. As long as the required documents are submitted, all Consigned Machines can be liquidated or changed to New Distributor and/or New Sponsor anytime. However, the change of Distributor and/or Sponsor can only be done once.

Cancellation of Distributorship

1. Distributor must return the unit/s in good condition.
2. All Sponsors must return all the commissions received from the cancelled and returned unit/s.
3. The refund shall be processed once the commissions have been surrendered.

Official Receipts

All Distributors are personally responsible for paying local and internal revenue taxes due on their earnings/commissions or any other earnings generated as a seller of Company products and services. The Company, as a withholding tax agent, is required by BIR to withhold applicable tax on income payments to distributors. The Distributors shall promptly provide any information, document and assistance which may be requested by the Company in order to comply with its responsibilities as the withholding agent.

As mandated by Section 237 of the Tax Code, as amended, taxpayers engaged in trade or business are required to issue Official Receipts (ORs) and/or Sales Invoices for each sale and transfer of goods and services, *to wit*:

(A) Issuance. – All persons subject to an internal revenue tax shall, **at the point of each sale and transfer of merchandise or for services rendered valued at One hundred pesos (P100) or more, issue duly registered receipts or sale or commercial invoices, showing the date of transaction, quantity, unit cost and description of merchandise or nature of service:** *Provided, however,* That where the receipt is issued to cover payment made as rentals, commissions, compensation or fees, receipts or invoices shall be issued which shall show the name, business style, if any, and address of the purchaser, customer or client: *Provided, further,* That where the purchaser is a VAT-registered person, in addition to the information herein required, the invoice or receipt shall further show the Taxpayer Identification Number (TIN) of the purchaser.

Within five (5) years from the effectivity of this Act and upon the establishment of a system capable of storing and processing the required data, the Bureau shall require taxpayers engaged in the export of goods and services, taxpayers engaged in e-commerce, and taxpayers under the jurisdiction of the Large Taxpayers Service to issue electronic receipts or sales or commercial invoices in lieu of manual receipts or sales or commercial invoices, subject to rules and regulations to be issued by the Secretary of Finance upon recommendation of the Commissioner and after a public hearing shall have been held for this purpose: *Provided,* That taxpayers not covered by the mandate of this provision may issue electronic receipts or, sales or commercial invoices, in lieu of manual receipts, and sales and commercial invoices.

The original of each receipt or invoice shall be issued to the purchaser, customer or client at the time the transaction is effected, who, if engaged in business or in the exercise of profession, shall keep and preserve the same in his place of business for a period of three (3) years from the close of the taxable year in which such invoice or receipt was issued, while the duplicate shall be kept and preserved by the issuer, also in his place of business, for a like period: *Provided,* That in case of electronic receipts or sales or commercial invoices, the digital records of the same shall be kept by the purchaser, customer or client and the issuer for the same period above stated.

The Commissioner may, in meritorious cases, exempt any person subject to internal revenue tax from compliance with the provisions of this Section.

Furthermore, under BIR Revenue Regulations No. 18-2012, these official and supplementary receipts are required to be registered with the BIR by securing an approval on the Authority to Print (“ATP”). Note that only BIR-accredited printers are allowed to print valid BIR receipts.

The failure to follow the BIR rules and requirements shall expose the Distributor to increased penalties under the Tax Code, as amended. He/she may be penalized with a fine of not less than Five Hundred Thousand Pesos (P500,000.00) but not more than Ten Million Pesos (P10,000,000.00) and imprisonment from six (6) to ten (10) years.

The inability of Distributors to issue ORs to support their income shall prevent the Company from releasing the necessary commissions/bonuses/other income due to said Distributors. Specifically, the issuance of ORs must be updated monthly.

Joint Business Venture Terms and Conditions

- 1. JV is allowed primarily for active distributors ranks 1A to 3A only**
2. Upline and Downline established this JV for purposes of accomodating commissions of the Downline from business with Enagic Philippines Inc. Thru Upline's issuance of it's Official Receipt, while the Downline is processing its BIR registration and acquisition of its own official receipt.
3. The term of the Joint Venture Agreement shall commence on the execution date and shall continue until the downline has completed BIR registration and has the capacity to issue own official receipt.
4. Discontinuance or termination of this Joint Venture Agreement shall be made in writing through cancellation letter by mutual consent of the Upline and Downline.
5. Only distributors with no accountabilities, updated official receipts issued, updated consignment liquidations, with clean records are allowed to enter into Joint Venture Agreement as an Upline, regardless of their rank and group line.
6. Only active distributor is allowed to enter Joint Venture Agreement as a downline.
7. It is the responsibility of the Downline to monitor and ensure that commissions are covered by official receipts that the Upline shall issue as soon as Statement of Account (wherein commissions of the Downline is reflected) is received from Enagic Philippines Inc.
8. Dowline may share commissions with the Upline to cover taxes that the Upline may incur in the event that the accommodated commissions shall become taxable.
9. Joint Venture Agreement list of requirements:
 - Fully signed and notarized Joint Venture Agreement Form.
 - Scanned valid ID of both Upline and Downline.
 - Accomplished clearance form from Consignment, Compliance, Collection Department.
 - Screenshot of last enrolled sales of Downline (to verify if they are active distributor).

Releasing of BIR 2307 and Submission of Official Receipts

1. The release of BIR Form 2307 (Certificate of Creditable Tax Withheld at Source) shall start from the 10th day of the month of the last quarter.
(Example: BIR 2307 for January-March 2018 may be released starting 10 April onwards.)
2. The submission of original ORs must be made within seven (7) days to fifteen (15) days from the receipt of commissions. Should the Distributor fail to comply within the aforesaid period, any expected commissions shall be automatically put on hold without further notice and advice.

Kindly submit your official receipts issued under our business name "Enagic Philippines, Inc." with TIN 007-767-804-000.

Releasing of E-Payment Commissions

E-payment commissions are divided into two (2) parts:

1. **First commission:** If the application of E-payment Distributor was registered, **the release of first commission will be seven (7) to ten (10) working days** upon registration. All commissions, including first commission, shall be deposited directly to Distributor's BDO Account.
2. **Closing/Pay Off Commission:** **The Company shall check if the monthly E-payment accounts are settled whenever they fall due.** If there are no delinquencies and an account is already fully paid, the closing/pay off commission will be processed and released every 5th of the second month. However, subject to Enagic' s sole discretion, the payoff commissions may be released earlier than the scheduled date.

For example, for all pay off accounts within March 01 – 20, 2018, the payoff commissions shall be released on May 05, 2018. For all pay-off accounts within March 21-31, 2018, pay off commission shall be released on May 25, 2018.

Commission Chart

MACHINE TYPE	K#	SP501	SP501-PT	JR W	SUPER501	ANESPA DX	EmGuarde (Member)	EmGuarde (Non Member)	UKON DD TEA/SCAP	UKON SIGMA TEA/SCAP	SUPER 501 (ESPA Member)	ANESPA DX (ESPA Member)	UKON DD (ESPA MEMBER)
UNIT PRICES	246,400	201,600	218,400	168,000	281,200	140,000	94,000	94,000	47,040	123,200	250,880	112,000	42,000
CASH													
SP	Php 15,000	Php 12,000	Php 12,000	Php 8,210	Php 16,000	Php 6,050	Php 4,911	Php 3,820	Php 1,900	Php 4,850	Php 12,800	Php 4,000	Php 1,500
Basic	Php 12,000	Php 9,600	Php 9,600	Php 6,600	Php 13,800	Php 5,650	Php 4,911	Php 3,820	Php 1,900	Php 4,850	Php 10,640	Php 3,000	Php 1,500
E-PAIEMENT													
1 st Commissions	Php 3,600	Php 2,880	Php 2,880	Php 1,980	-	Php 1,700	Php 1,050	Php 0	Php 0	Php 1,320	-	-	-
Closing Bonus w/ SP	Php 11,400	Php 9,120	Php 9,120	Php 6,230	-	Php 5,150	-	-	-	-	-	-	-
Closing Bonus w/o SP	Php 8,400	Php 6,720	Php 6,720	Php 4,700	-	Php 3,950	Php 3,061	Php 3,820	Php 1,900	Php 3,530	-	-	-
RCBC METROQUANTIME PAYMENT													
SP	Php 14,000	Php 11,100	Php 11,100	Php 7,460	Php 15,500	Php 6,225	Php 4,500	Php 3,550	Php 1,780	Php 4,445	Php 11,760	Php 3,500	Php 1,850
Basic	Php 11,000	Php 8,700	Php 8,700	Php 5,850	Php 12,500	Php 5,025	Php 4,500	Php 3,550	Php 1,780	Php 4,445	Php 9,520	Php 2,500	Php 1,850
BOC MOTO (ON-TIME PAYMENT)													
SP	Php 13,500	Php 10,900	Php 10,900	Php 7,460	Php 15,200	Php 6,000	Php 4,500	Php 3,550	-	-	Php 11,620	Php 3,435	Php 1,850
Basic	Php 10,500	Php 8,300	Php 8,300	Php 5,850	Php 12,200	Php 4,945	Php 4,500	Php 3,550	Php 1,780	Php 4,445	Php 9,380	Php 2,435	Php 1,850
BOC BPI CARD (ONE TIME PAYMENT)													
SP	Php 14,000	Php 11,200	Php 11,200	Php 7,460	Php 15,700	Php 6,300	Php 4,500	Php 3,550	-	-	Php 11,800	Php 3,560	Php 1,850
Basic	Php 11,000	Php 8,800	Php 8,800	Php 5,850	Php 12,700	Php 5,100	Php 4,500	Php 3,550	Php 1,780	Php 4,445	Php 9,660	Php 2,560	Php 1,850
BOC CREDIT CARD INSTALLMENT													
12 Months	SP	Php 11,000	Php 8,400	Php 5,960	Php 12,500	Php 4,975	-	-	-	-	Php 9,520	Php 2,500	Php 1,420
	Basic	Php 8,000	Php 6,000	Php 4,350	Php 9,500	Php 3,775	Php 3,570	Php 2,070	Php 1,345	Php 3,360	Php 7,280	Php 1,500	Php 1,420
24 Months	SP	Php 8,200	Php 7,000	Php 4,270	Php 9,150	Php 3,565	-	-	-	-	Php 7,000	Php 1,750	Php 940
	Basic	Php 5,200	Php 4,300	Php 2,660	Php 6,150	Php 2,305	Php 2,420	Php 1,720	Php 875	Php 2,140	Php 4,780	Php 790	Php 940
METROQUANTIME CREDIT CARD INSTALLMENT													
12 Months	SP	Php 11,500	Php 9,200	Php 5,960	Php 12,800	Php 5,130	-	-	-	-	Php 9,520	Php 2,605	Php 1,420
	Basic	Php 8,500	Php 6,800	Php 4,350	Php 9,800	Php 3,930	Php 3,670	Php 2,770	Php 1,945	Php 3,360	Php 7,280	Php 1,605	Php 1,420
24 Months	SP	Php 9,500	Php 7,400	Php 4,270	Php 10,200	Php 4,035	-	-	-	-	Php 7,840	Php 1,375	Php 940
	Basic	Php 6,500	Php 5,000	Php 2,660	Php 7,200	Php 2,835	Php 3,000	Php 2,200	Php 875	Php 2,140	Php 5,660	Php 875	Php 940
BPI CREDIT CARD INSTALLMENT													
12 Months	SP	Php 11,000	Php 9,000	Php 5,960	Php 12,500	Php 4,975	-	-	-	-	Php 9,520	Php 2,500	Php 1,420
	Basic	Php 8,000	Php 6,600	Php 4,350	Php 9,500	Php 3,375	Php 3,570	Php 2,070	Php 1,345	Php 3,360	Php 7,280	Php 1,500	Php 1,420
24 Months	SP	Php 9,500	Php 7,400	Php 4,270	Php 10,200	Php 4,035	-	-	-	-	Php 7,840	Php 1,750	Php 940
	Basic	Php 6,500	Php 5,000	Php 2,660	Php 7,200	Php 2,835	Php 2,520	Php 1,720	Php 875	Php 2,140	Php 5,660	Php 750	Php 940
RCBC CREDIT CARD INSTALLMENT													
12 Months	SP	Php 11,500	Php 9,200	Php 5,960	Php 12,800	Php 5,130	-	-	-	-	-	-	Php 1,420
	Basic	Php 8,500	Php 6,800	Php 4,350	Php 9,800	Php 3,930	Php 3,570	Php 2,070	Php 1,345	Php 3,360	-	-	Php 1,420
24 Months	SP	Php 10,000	Php 8,400	Php 4,270	Php 10,900	Php 4,050	-	-	-	-	-	-	Php 940
	Basic	Php 7,000	Php 5,600	Php 2,660	Php 7,900	Php 2,850	Php 3,000	Php 2,200	Php 875	Php 2,140	-	-	Php 940

Basic 8-Point Commission Structure

This structure applies to all Enagic products, although the commission point value may vary for each product. The basic 8-point commission structure is the foundation from which each Distributor begins with Enagic product sales.

There are 6 ranks (1A up to 6A) and each ranks have eight (8) levels .

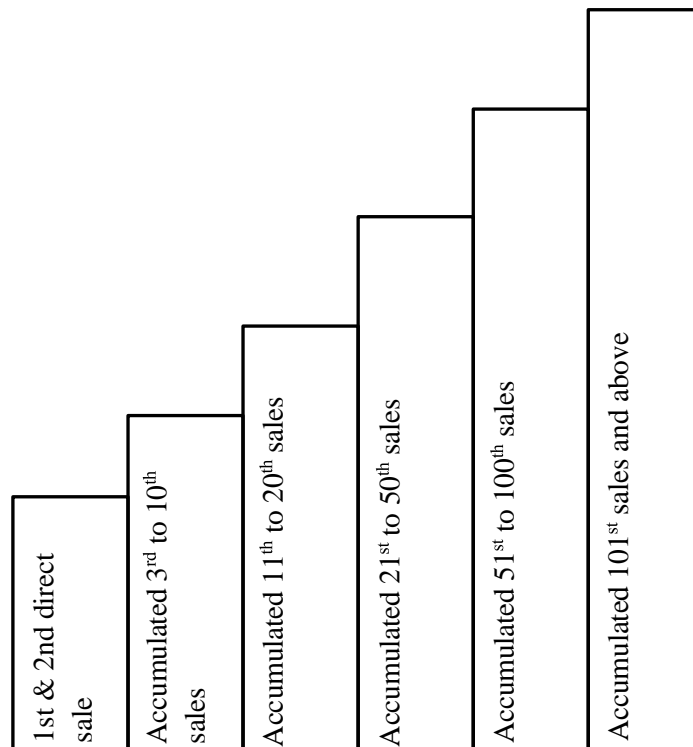

Advancement of Rank

Rank advancement is based on a combination of direct and group sales, and is not limited to one (1) rank at a time. An advancement in rank is always initiated by a direct sale, but a Distributor will advance to whichever rank he is qualified for based on total accumulated sales volume. Once a rank is achieved, it will be maintained until the next rank is attained. There will be no need for a Distributor to start over and Distributors ranked 2A and higher can have an unlimited number of direct sales.

The following are the requirements for each rank:

1A Distributor - Qualifications to Achieve this Rank:

- Be able to sell one (1) unit, wherein a unit sold to oneself will be counted as a sale.
- For every direct sale made, a new 1A Team will be selling beneath you.

Example: 1A Line

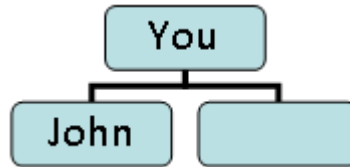

Sales = SD501 = Php 12,000/ point

Your Bonus = 1A = Php 12,000

- John will be your 1A Line.
- You will always receive overriding maximum of “1 point” from this line.

2A Distributor - Qualifications to Achieve this Rank:

- You must first be a 1A Distributor.
- Must have accumulated direct sales of two (2) units.
- You will be paid as a 2A distributor after your 3rd direct sale.
- Each direct sale that is made as a 2A represents a new 2A team selling beneath you.

Example:

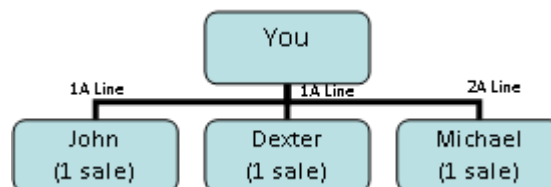

- Michael will be your 2A Line.
- You will always receive overriding maximum of “2 points” from this line.

3A Distributor - Qualifications to Achieve this Rank:

- Accumulated total sales of **ten (10) units**, whether direct or indirect.
- You will be paid as a 3A Distributor upon your next direct sale.
- Each direct sale that is made as a 3A represents a new 3A team selling beneath you.

Example:

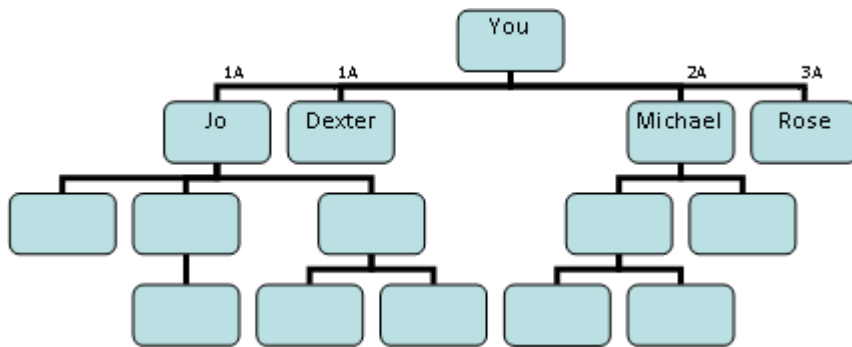

- Rose will be your 3A Line.
- You will always receive overriding maximum of “3 points” from this line.

4A Distributor - Qualifications to Achieve this Rank:

- Accumulated total sales of **twenty (20) units**, whether direct or indirect.
- You will be paid as a 4A distributor upon your next direct sale.
- Each direct sale that is made as a 4A represents a new 4A team selling beneath you.

Example:

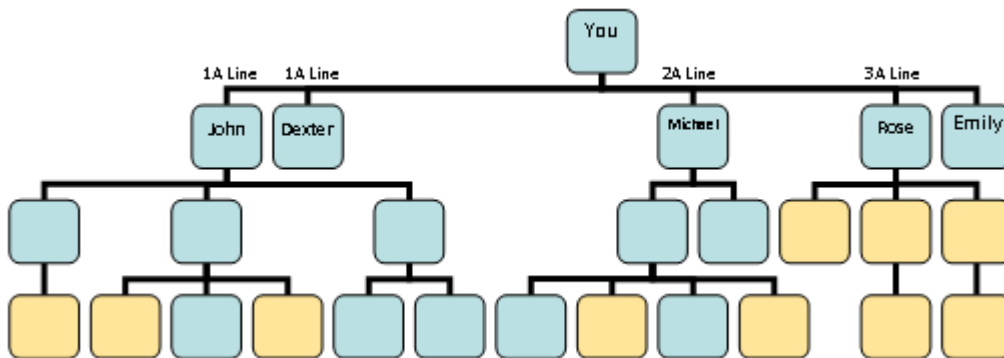

- Emily will be your 4A Line.
- You will always receive overriding maximum of “4 points” from this line.

5A Distributor - Qualifications to Achieve this Rank:

- Accumulated total sales of **fifty (50) units**, whether direct or indirect.
- You will be paid as a 5A distributor upon your next direct sale.
- Each direct sale that is made as a 5A represents a new 5A team selling beneath you.

Example:

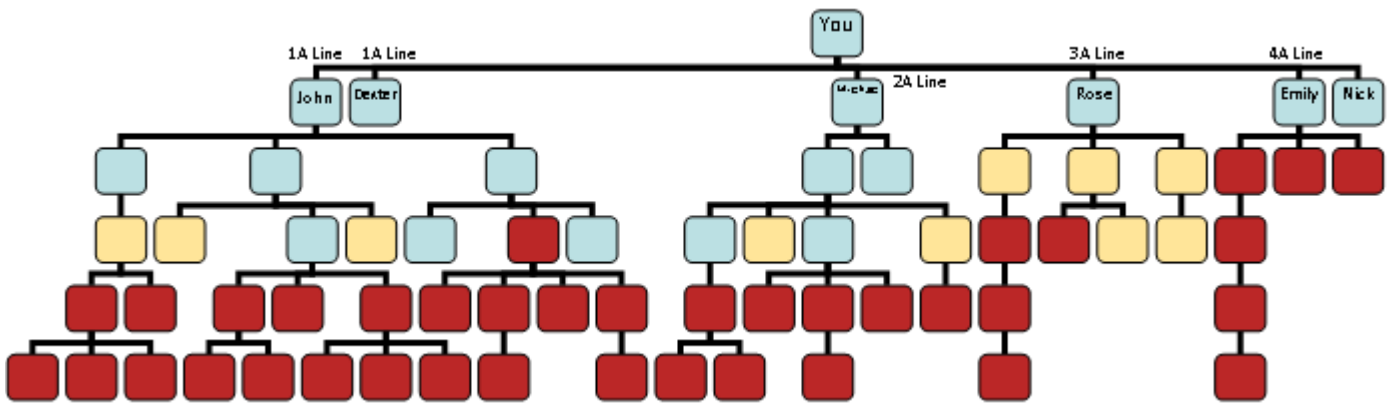

- Nick will be your 5A Line.
- You will always receive overriding maximum of “5 points” from this line.

6A Distributor - Qualifications to Achieve this Rank:

- Accumulated total sales of (one hundred) **100 units**, whether direct or indirect.
- You will be paid as a 6A distributor upon your next direct sale.
- Each direct sale that is made as a 6A represents a new 6A team selling beneath you.

Example:

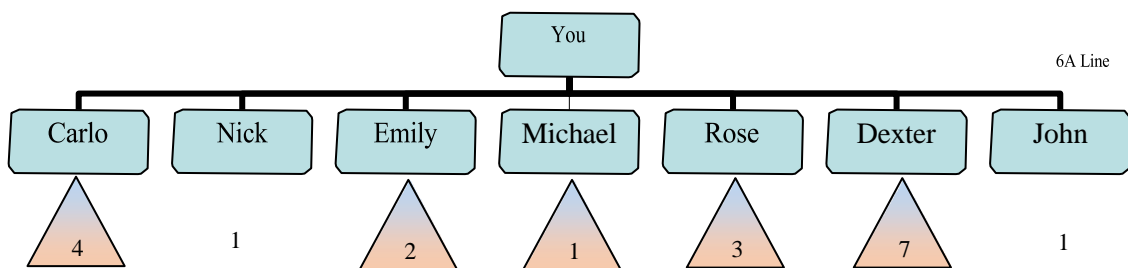

- Carlo will be your 6A Line.
- You will always receive overriding maximum of “6 points” from this line.

Examples

1.)
Position

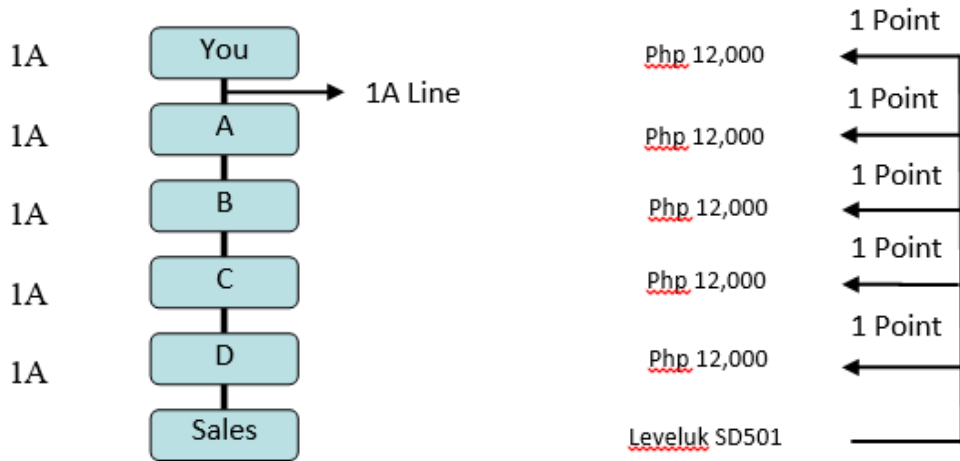

- You will receive Php 12,000

2.)

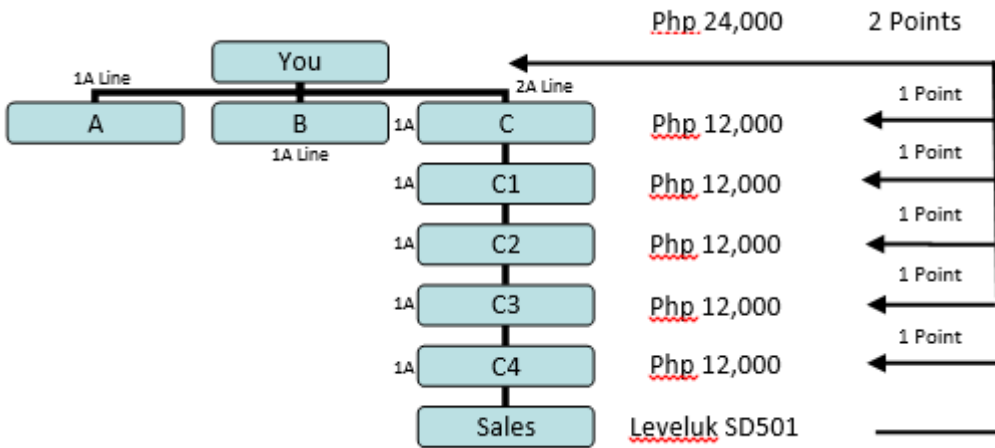

- "C" is your 2A line, and you will enjoy 2 points which is Php 24,000 for sales from this group.
- You will be receiving Php 24,000 for the scenario above because you fall into the 8 points system.

3.)

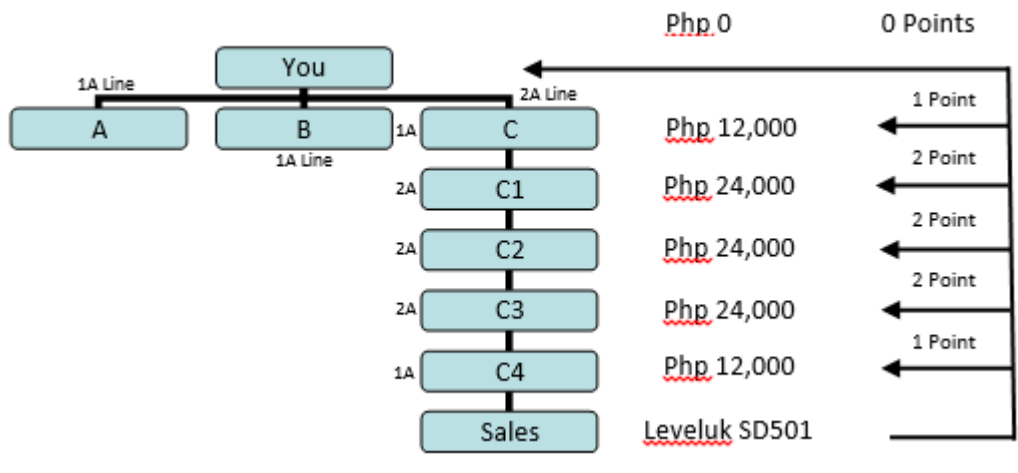

- You will not receive any overriding for the sales due to 8 points have been fully paid out.

4.)

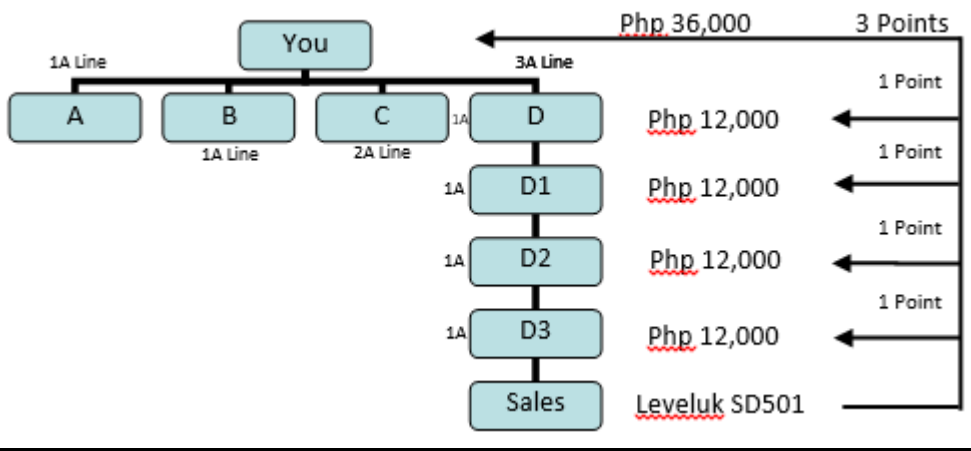

- "D" is your 3A line, and you will enjoy 3 points/ Php 36,000 for those sales from this group.
- You will be receiving Php 36,000 for the scenario above because you fall into the 8 points system.

5.)

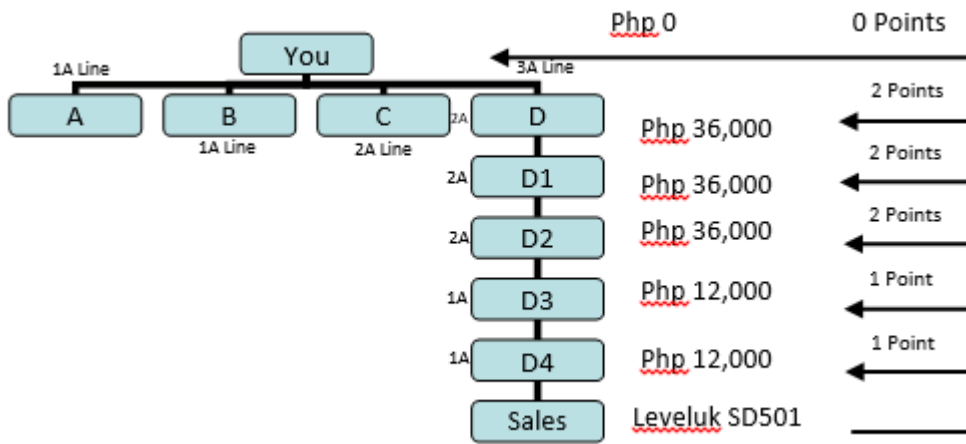

- You will not receive any overriding for the sales due to 8 points have been fully paid out.

6.)

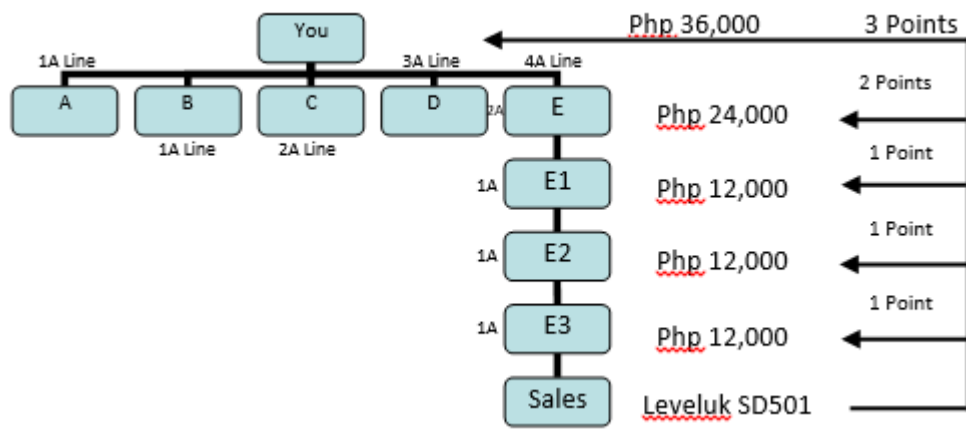

- "E" is your 4A line, and you will enjoy maximum 4 points/ Php 46,000 for those sales from this group.
- You will be receiving Php 36,000 only for the scenario above because you are only left 3 points from the 8 points system, even if you are eligible to get 4 points.

7.)

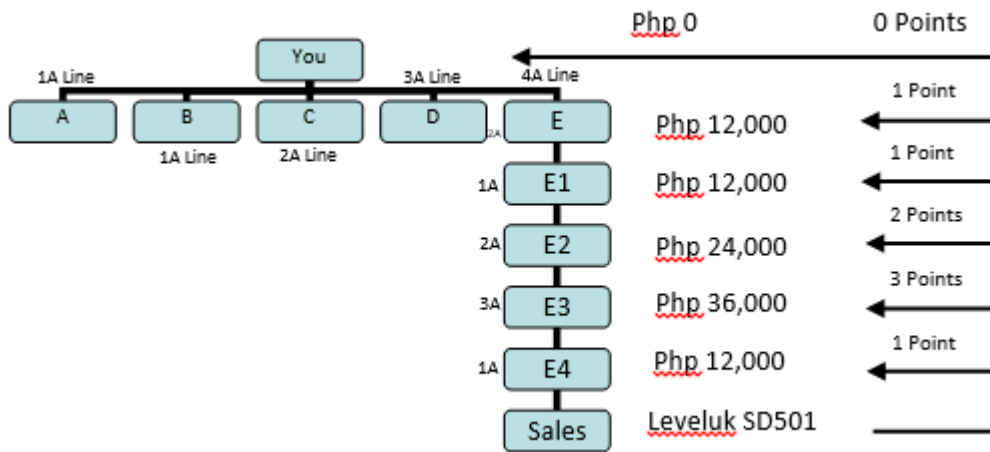

- You will not receive any overriding for the sales due to 8 points have been fully paid out.
- "E" will only receive Php 12,000 even if "E" was eligible to get P24, 000 (2 points).

8.)

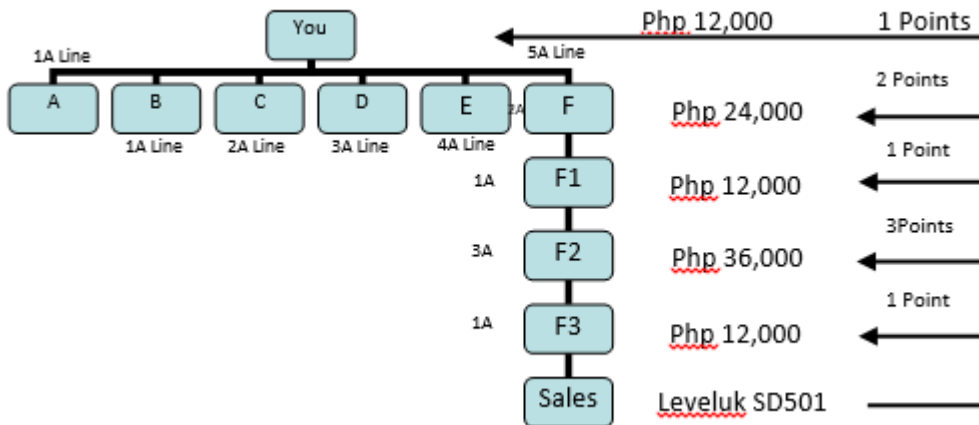

- "F" is your 5A line, and you will enjoy maximum of 5 points/Php 60,000 for those sales from this group.
- You are receiving Php 12,000 only for the scenario above because you are only left 1 point from the 8 points system, even if you are eligible to get 5 points.

9.)

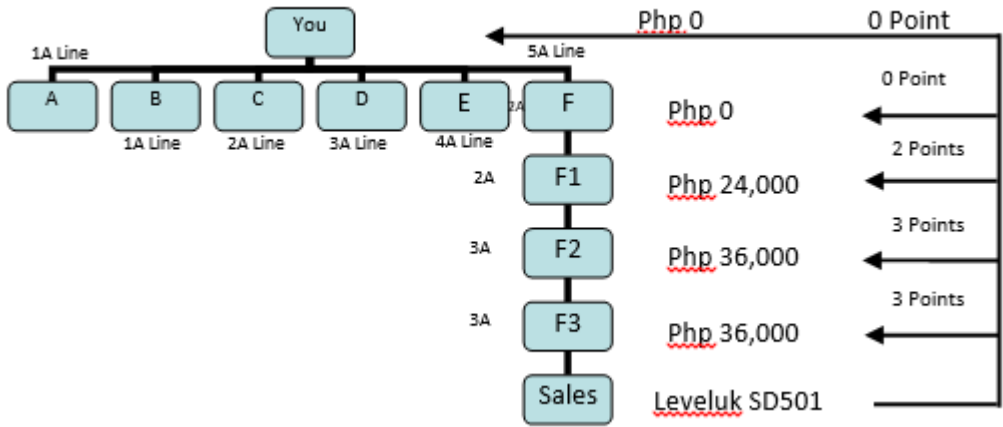

- You will not receive any overriding for the sales due to 8 points have been fully paid out.
- "F" will not receive any overriding, although "F" was eligible to Php 24,000 (2 points) because the 8 points have been fully paid out.

10.)

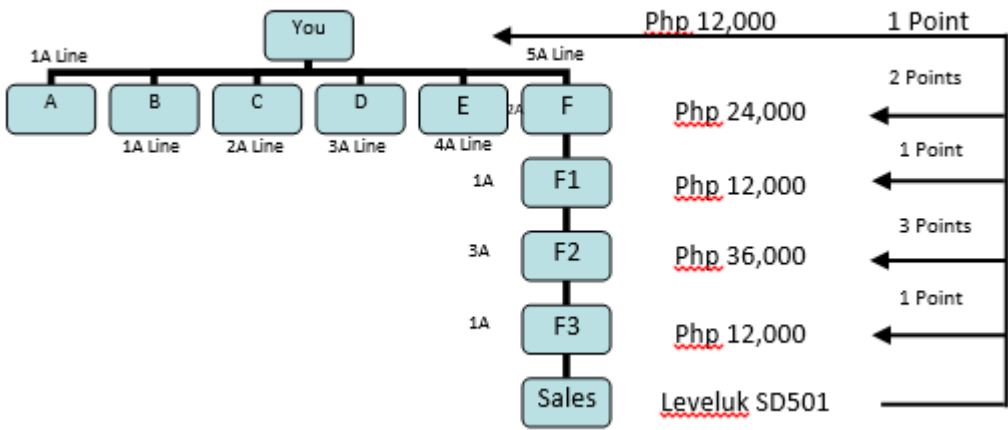

- "F" is your 5A line, and you will enjoy maximum 5 points/ Php 60,000 for those sales from this group.
- You 1 point from the 8 points system, even if you are eligible to 5 points.

11.)

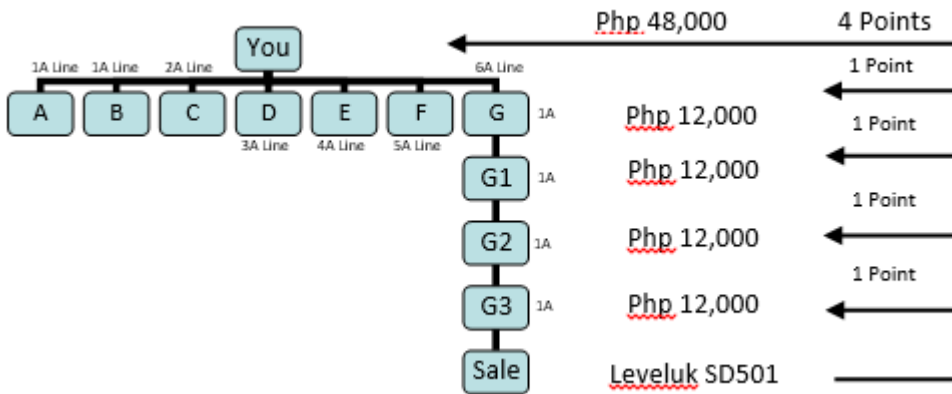

- "G" is your 6A line, and you will enjoy maximum 6 points/ Php 72,000 for those sales from this group.
- You are receiving Php 48,000 only for the scenario above because you are only left 4 points from the 8 points system, even if you are eligible to 6 points.

12.)

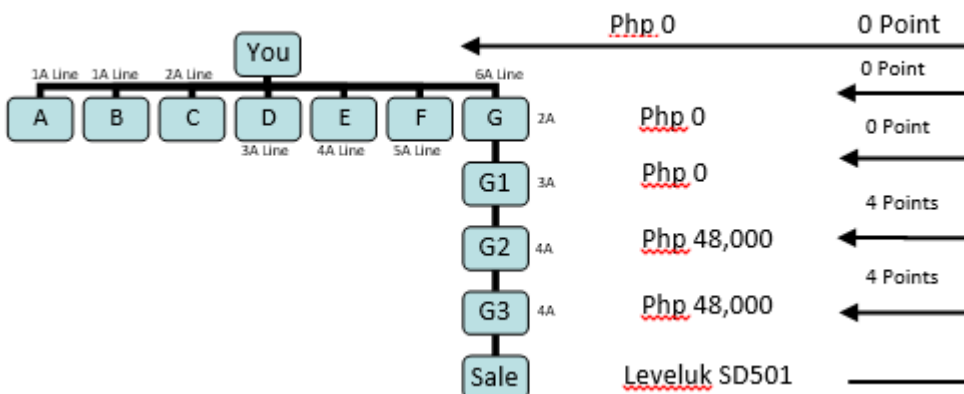

- You will not receive any overriding for the sales because the 8 points have been fully paid out.
- "G" & G1" will not receive any overriding, even if "G" was eligible to get Php 24,000 (2 points) & "G1" was eligible to get Php 36,000 (3 points) because the 8 points have been fully paid out.

UKON DD and SIGMA 8-point Commission Structure (Pass-up system)

Example No. 1

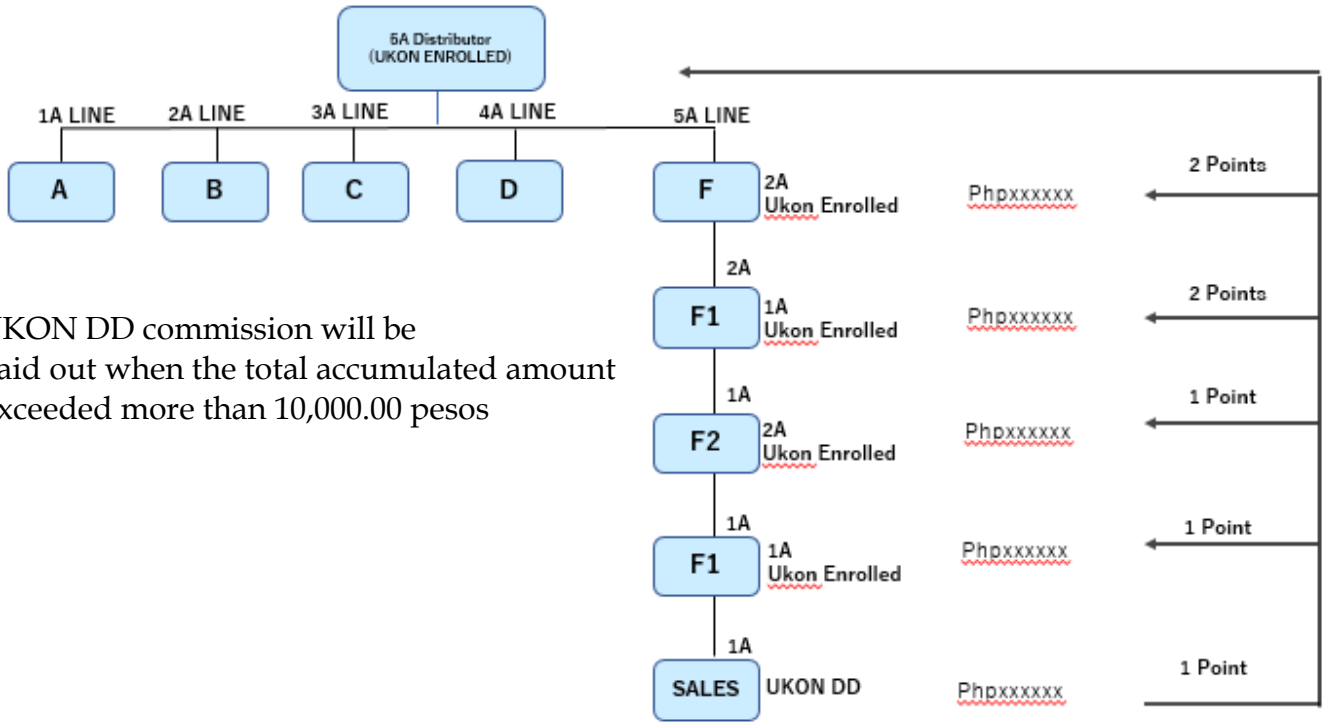

For commission amount of UKON DD and SIGMA, please check the Commission chart.

Example No. 2 - With Skip (Pass-Up)

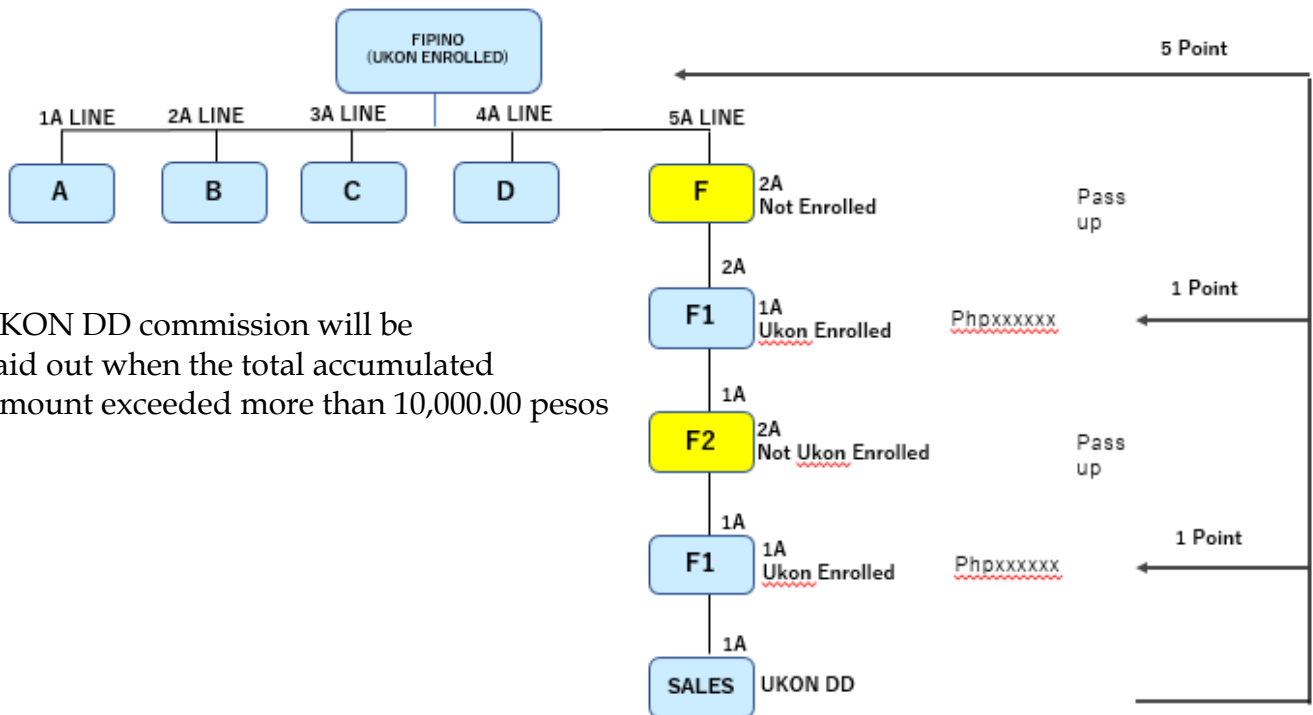

For commission amount of UKON DD and SIGMA, please check the Commission chart.

Educational Bonus

MODEL	COMMISSION BASE	LEVEL of 6A FROM SALE	AMOUNT
K8	SP	2-3	PHP 2,325.00
		1	PHP 9,300.00
	BASIC	2-3	PHP 1,950.00
		1	PHP 7,800.00
SD 801 PT	SP	2-3	PHP 2,325.00
		1	PHP 9,300.00
	BASIC	2-3	PHP 1,950.00
		1	PHP 7,800.00
SD 501	SP	2-3	PHP 2,325.00
		1	PHP 9,300.00
	BASIC	2-3	PHP 1,950.00
		1	PHP 7,800.00
ANESPA	SP	2-3	PHP 1,350.00
		1	PHP 5,400.00
	BASIC	2-3	PHP 1,140.00
		1	PHP 4,560.00
JR IV	SP	2-3	PHP 1,400.00
		1	PHP 6,400.00
	BASIC	2-3	PHP 1,200.00
		1	PHP 5,000.00
SUPER 501	SP	2-3	PHP 3,450.00
		1	PHP 13,800.00
	BASIC	2-3	PHP 2,850.00
		1	PHP 11,400.00

6A Step Up Bonus

Step No.	6A Step units	Accumulated Units	6A up line
1	96 - 101	0 - 5	P57,200.00
2	91 - 95	6 - 10	P53,680.00
3	86 - 90	11 - 15	P49,720.00
4	81 - 85	16 - 20	P45,760.00
5	76 - 80	21 - 25	P42,240.00
6	71 - 75	26 - 30	P38,280.00
7	66 - 70	31 - 35	P36,520.00
8	61 - 65	36 - 40	P34,320.00
9	56 - 60	41 - 45	P32,560.00
10	51 - 55	46 - 50	P30,800.00
11	46 - 50	51 - 55	P28,600.00
12	41 - 45	56 - 60	P26,840.00
13	36 - 40	61 - 65	P25,520.00
14	31 - 35	66 - 70	P22,880.00
15	26 - 30	71 - 75	P21,120.00
16	21 - 25	76 - 80	P18,920.00
17	16 - 20	81 - 85	P17,160.00
18	11 - 15	86 - 90	P14,080.00
19	6 - 10	91 - 95	P12,320.00
20	5	96	P8,360.00

1. To qualify in the 6A Step Up bonus, you must have sold within the month a minimum of 5 units.
2. The Step-Up bonus shall be computed based on the number of units sold for the month to achieve 6A.
3. When a Distributor is qualified to become a 6A Distributor, the bonus shall be paid to the former's closest 6A Distributor. The bonus will be paid one (1) month after the Distributor became a 6A Distributor.
4. The 6A Distributor will be paid for six (6) months for the 1st new 6A in your downline. For the 2nd new 6As, you will be entitled to be paid for one (1) month. Afterwards, your entitlement to Step Up bonuses will stop.
5. One line only allows one 6A, if one line have two cross lines would consider as one line.
6. If a new 6A 101 units sold, at least 51 units are registered in Philippines.
7. The Machines bought through the E-payment scheme will be considered in counting the number of units sold to qualify in this bonus.
8. Three (3) Ukon units will be counted as if it is only one (1) unit.

6A Group Unit Bonus

Group unit of the month	Direct Sales			
	0 unit	1 unit	2 units	3 units and above
Group sales under 4	PHP 8,800	PHP 17,600	PHP 32,500	PHP 52,800
5 - 9	PHP 11,000	PHP 22,000	PHP 44,000	PHP 66,000
10 - 14	PHP 22,000	PHP 44,000	PHP 66,000	PHP 88,000
15 - 19	PHP 33,000	PHP 66,000	PHP 88,000	PHP 110,000
20 - 24	PHP 44,000	PHP 88,000	PHP 110,000	PHP 132,000
25 - 29	PHP 55,000	PHP 110,000	PHP 132,000	PHP 154,000
30 and above	PHP 66,000	PHP 132,000	PHP 154,000	PHP 176,000

1. The award will be paid for the following six (6) months after becoming a 6A Distributor.
2. Direct sale - the direct sale of the new 6A following six months.
3. The sales made beyond 8P shall also be considered. However, the units sold by the 6A Distributor's down-line shall not be considered.
4. The sales made by Tokurei Distributors shall not be counted as a group sale.

Title Incentives

No	Rank	Title incentive
1	6A	PHP 135,000
2	6A2	PHP 270,000
3	6A2-2	PHP 540,000
4	6A2-3	PHP 1,125,000
5	6A2-4	PHP 2,250,000
6	6A2-5	PHP 4,500,000
7	6A2-6	PHP 9,000,000

1. When you step up to 6A, you must have more than 10 sales within 8 points.
 2. Total sales value must exceed USD300,000 (Cancellations and Tokurei do not count)
 3. Ukon counts 3 = 1 unit
 4. Ukon Signa counts as 1 unit
 5. Only 5 Tokurei Accounts are counted.
- 6A title incentive only has 2nd, 3rd chance to be qualified.

6. 6A2 above title incentives has no 2nd chance.

Additional Rule for Achieving 6A Rank

Current rule

- 101th unit (within 8-Point) makes 6A line.
- Note that, excluding the cancellations, only up to 5 Tokurei registrations are allowed.

NEW RULE

- The Distributor will be recognized as a 6A Distributor in the following month after these two (2) conditions are met.
 - 101th unit (within 8-Point) makes 6A line. Note that, excluding the cancellations, only up to 5 Tokurei registrations are allowed.
 - Total sales value must exceed USD300,000. The cancellations and Tokurei do not count, Tokurei cancellations are counted. This rule is applicable to Distributors becoming 6A after July 2018.
- You can make a 6A line with 101th unit sale (direct sale) as before. Ukon DD and E8PA card, however, cannot make the first 6A line. Product price in USD (For ALL areas).
- **Important calculation changes to the 6A and Above Title Incentives effective February 1,2024.**
 - **A Distributor who ranks up to 6A with only 1A lines will receive 1/6 of the title incentive. Their upline will also receive 1/6 of their own title incentive.**
 - **A Distributor who ranks up to 6A with only 2A lines will receive 2/6 of the title incentive. Their upline will also receive 2/6 of their own title incentive.**
 - **A Distributor who ranks up to 6A with only 3A lines will receive 3/6 of the title incentive. Their upline will also receive 3/6 of their own title incentive.**
 - **A Distributor who ranks up to 6A with only 4A lines will receive 4/6 of the title incentive. Their upline will also receive 4/6 of their own title incentive.**
 - **A Distributor who ranks up to 6A with only 5A lines in their downline will receive the full title incentive. Their upline will also receive the full title incentive.**

Products	USD
S501	5,980
S501 Membership	5,250
K8	4,980
SD501U	4,980
SD501PT	4,280
SD501	3,980
Anespa DX	2,890
JR IV	2,980
Anespa DX Membership	2,300
UkonΣ	1,980
UkonDD	760
E8PA Blk	8,000
E8PA Slv	6,000
E8PA Gld	4,000
E8PA Plt	2,000
E8PA Brz	1,000

Example:

The calculation below applies to ALL areas.

$$\begin{aligned}
 &\text{UkonDD 30 sales} \times \text{USD760} = 22800 \\
 &\text{SD501 60 sales} \times \text{USD3,980} = 238,800 \\
 &\text{K8 11 sales} \times \text{USD4,980} = 54,780 \\
 &\qquad\qquad\qquad \underline{\text{Total 101 sales}} = \underline{\text{USD316,380}}
 \end{aligned}$$

Achieving a rank of 6A will gain further significance with this new rule. Distributors mainly selling SD501 will achieve 6A as before.

Incentives Relating to Additional Rule for Achieving 6A

• Title incentive

Available with over 10 sales in the month qualifying for 6A. (3 Ukon DD=1 unit, up to 5 Tokurei are allowed)

Will receive full incentive even if UkonDD makes over 30% of total sales when total sales value exceeds USD300,000. If not qualified for the incentive with less than 10 sales, you still have chance for the incentive with 15 or more sales in 2 months, or 20 or more sales in 3 months.

• Step-up Bonus

Difference between 101th sales is counted in the month qualifying for 6A.

If you already have over 101 sales by the month qualifying for 6A, you are qualified for Step 20 (\$190) with 4 or more sales within the month.

To check sales value in USD

We are now working on adding value in USD in Sales Reports and 6A Candidate List.

6A8 Level Monthly Group Incentive

Qualification Criteria: 6A2 Distributors and above qualify for this incentive as long as the 6A2 Distributors and 6A2-2 have sold at least one (1) unit and 2 units, respectively, within the 8-point sales* and after all cancellations have been deducted.

Type #1

The incentives per 8-Level 6AGroup sale are:

- For 6A2 Distributors: P840.00 per 8-level (6A) group sale
- For 6A2-2 Distributors: P920.00 per 8-level (6A) group sale

Type #2

Whenever there is an Open Volume Sale, ** the P1,680.00 multiplier will be applied to the same.

Moreover, when ten (10) or more Open Volume Sales** are accumulated, an additional P1,200.00 will be added to the incentive per sale.

Here is a summary of the computational method used for the Incentive. (Please note the Ukon will be counted as 3 = 1 ratio)

** Open Volume Sale: A sale that does not have any 6A Distributor between you and the sale regardless if the sale falls within your 8-point or not.

6A 8 Level Quarterly Group Incentive

Qualification Criteria: 6A2 distributors and above qualify to this incentive as long as the 6A2 Distributors and 6A2-2 have sold have sold at least three (3) units and six (6) units, respectively, within the 8-point sales* and after all cancellations have been deducted.

Types:

#1. 6A 8-level group sales incentive

6A 8-level group sales x P590.00 -----A

#2. Title incentive

6A2 title incentive P42,000 and 6A2-2 title incentive P84,000 -----B

#3. 6A line bonus

One additional 6A line (counted from 6A3) x P21,000 -----C

*** Ukon units counted 3=1 sale

Collection Rate & Bonuses Chart

(For 6A, 6A2, 6A3, 6A22, 6A23, 6A24, 6A25, 6A42)

COLLECTION RATE FOR ALL RANKS (%) (Based on immediate 6A Group)	DEDUCTION (%)					
	6A	6A2/6A3/6A4	6A22/6A42	6A23	6A24	6A25
80% Above	NO DEDUCTION	NO DEDUCTION	NO DEDUCTION	DEDUCTION WILL BE BASED ON THE 6A23 and ABOVE BONUS CALCULATIONS		
75-79 %	4%	3.80%	3.10%			
70-74 %	5%	4.60%	4.40%			
65-69 %	8%	6.80%	6%			
60-64 %	11%	9%	8.70%			
55-59 %	14%	11.20%	10%			
50-54 %	17%	13.50%	11%			
49 % Below	20%	15.70%	12%			

For all 6A Distributors and above, the BONUSES shall be deducted based on the MONTHLY COLLECTION RATE as provided in the chart above.

Examples:

1. 6A Bonus = Php50, 000 and Collection Rate = 66% of your 6A Group

Amount of deduction to be made = P50,000 × (8% based on the chart above)

= P4,000

Computation: P50,000 - P4,000 = **a total of P46,000 6A Bonus will be received**

2. 6A22 Bonus = Php100, 000 and Collection Rate = 51% of your 6A Group

Amount of deduction to be made = P100,000 × (11% based on the chart above)

= P11,000

Computation: P100,000 - P11,000 = **a total of P89,000 6A22 Bonus will be received**

Note: All deducted amounts shall be equally divided into your delinquent downlines and will be considered as their monthly payments. Enagic reserves the right to use a portion of the deducted amount for the purpose of collecting from your delinquent downlines.

Machine Repair Instructions

It is VERY IMPORTANT to follow the procedures below to avoid delays in the release of repaired Machine(s). Please note that the Company does not perform any repair services outside its office.

Procedures:

1. Bring the Machine for repair directly to the office of Enagic near you. The client will be assisted by the technician i.e., initial assessment and evaluation of the Machine. The initial assessment and evaluation report shall be in writing via the Technician Form and to be duly signed/acknowledged by the client.
2. The technician will fill-up the Itinerary Form based on his findings reflected in the Technician Form. Client will again sign his conforme on the Itinerary Form.
3. The Technician and Itinerary Forms will be forwarded to the Collection Department in order to assess the client's payment history. The Collection Department shall indicate the following in the Itinerary Form:
 - a) Distributor's ID number,
 - b) Machine purchase date,
 - c) Client's payment history assessment and
 - d) Approval to proceed with the services as indicated in the Itinerary Form.
4. Should the Collection Department disapprove the request for repair, the Machine will be put on hold by Enagic.
5. Once approved by the Collection Department, the technician shall proceed to process Master Data, Service Contract and Service Call in the Systems Application & Products (SAP) and to generate sales order.
6. The technician shall receive the payment from the client and turn over the same to the cashier for the issuance of sales invoice for those parts not covered by the warranty and an official receipt for services to be performed.
7. The billing/sales invoice and official receipt will be given to the client together with a copy of the generated Service Call. Enagic shall not release the Machine unless the following is presented:
 - a) Service Call
 - b) Official Receipt
 - c) Billing/Sales Invoice
8. Upon presentation of the Service Call and Billing/Sales Invoice and the release of the Machine, the technician shall stamp those with "RELEASED."

Important Notes:

1. The office shall accept Machines for repair only from 10:00 AM up to 5:00 PM.
2. The buyers, whose warranties on their respective Machines have already expired, may avail of the extended warranty from the technician. Note, however, that the extended warranty will not cover 110V power supply.
3. To release the Machine, the client shall pay the shipping charges to and from chosen office of Enagic. Also, the service call and billing/sales invoice should be sent first to Enagic before the Machine can be shipped back to the client.
4. Client may opt to send the Machine through courier. Please note of the following:

Service Area	Name of Department	Services Covered	Type of Machines	Duration of Service Rendered
Luzon - Manila Office	Service - Manila	All services may be provided	All types of units	Max of fourteen (14) working days
Visayas - Cebu Service Center	Service - Cebu	All services may be provided	SD501, DXII, JRIV, SD501-PT, Leveluk R and Super501	Max of seven (7) working days
Mindanao - Davao Service Center	Service - Davao	All services may be provided	SD501, DXII, JRIV, SD501-PT Leveluk R and Super501	Max of seven (7) working days

5. **Leveluk R and Leveluk JR II machine are phased-out model however technical support is still being offered.**

Payment Options

1. Cash deposit

Bank Name	BDO Unibank Inc.
Account Name	Enagic Philippines, Inc.
Account Number	8230028457

The original bank validated deposit slip should be presented to the Enagic Office upon turnover of the Machine to the technician.

2. Credit card (Visa, Mastercard and American Express)
The credit card may be swiped at any Enagic office or via Mail Order/Telephone Order (MOTO).
3. **NO CASH POLICY.**

Services

1. Deep Cleaning **is required** for all types of water Machine every six (6) months.
2. Under normal circumstances, the services shall be completed within approximately fourteen (14) working days from the date of receipt of payment.
3. The following are the fees for Deep Cleaning:

Type of Machine	Deep Cleaning Fee	Repair under warranty	If warranty is expired
SD501, SD501-PT & JRIV	P2,200	Free of charge (based on Consumer Limited Warranty)	The regular fees will apply if there is no extended warranty.
K8 and Super 501	P2,900		

The Deep Cleaning Express, which will be completed within 3-5 working days, for Manila and Davao has an additional fee of P1,000.00.

For queries regarding the repair services, please feel free to call the following:

Enagic Manila Office:

E-mail Address: service-manila@enagic.ph

Address: Units 3 & 4, 16F A.T. Yuchengco Centre, 26th & 25th St. BGC, Taguig City

Tel. No.: (02) 8519-5508 local 150

CONSUMER LIMITED WARRANTY

- Enagic warrants to the original purchaser that the Leveluk brand product, shall be free from defective workmanship and materials and agrees that it shall, at its option, either repair or replace the defective product or part at no charge to the original purchaser within the period provided below.
- This warranty shall not apply to the following:
 1. additional items bought, such as: flexible pipe, hoses, accessories and printed materials
 2. deep cleanings,
 3. when there is an electrolysis enhancer damage, improper voltage, misuse and abuse of unit, Machine alteration, damage caused by natural disasters and shipping/courier mishandling of products sent to Enagic for any service other than repair(s).
 4. exterior of the unit if such has been damaged or defaced due to improper voltage, misuse, abnormal service or has been altered or modified in design or construction
 5. tampered Machines
- The limited warranty described herein shall be in addition to the implied warranties granted by law. All implied warranties, including the warranties of merchantability and fitness for use, shall be limited to **three (3) years from the date of purchase** with respect to parts and labor. However, the warranty shall be respected only if the electrolysis chamber is kept clean with an E-Cleaner. As a prerequisite for availing the warranty, the E-Cleaner must be applied once every two (2) weeks and such can be purchased separately as an optional maintenance kit.
- In order to enforce the rights under this limited warranty, the purchaser must follow the Machine's Operating Manual, procedures set forth herein and must provide the proof of purchase to the Company.
- Neither the sales personnel of Enagic nor any other person is authorized to make any warranties or to extend the duration of the warranties beyond the period described herein on behalf of Enagic.
- In no event will Enagic be liable or in any way be responsible for any damage or defect in the product which were caused by repairs performed by anyone other than an authorized service representative.

Extended Consumer Limited Warranty

- This extended consumer limited warranty is valid solely for Machines purchased and intended for use in the Philippines.
- Any damage incurred outside of the country of purchase, including, but not limited to damage caused by incorrect wattage, incorrect voltage and unsuitable/unsafe water source, is not covered by this limited warranty. The use of 3rd party filter will also void warranty.
- This warranty is non-transferable unless a written permission has been provided by Enagic for the transfer.
- Be sure to have the model and serial number available when you seek service for your product.
- Please include the Extended Warranty Card with the Machine when you will request for deep cleaning, otherwise, you will be charged. Please make sure that the label "Extended Warranty" is protected from water when the Machine is shipped for deep cleaning.
- You will be charged with the regular price for the repair of the Machine if it is out of warranty at the time of its arrival in the Enagic office.



Enagic Philippines, Inc.
Units 3 & 4, 16F A.T. Yuchengco Centre,
25th and 26th Streets, Bonifacio Global City, 1634
Taguig City
Tel. No. (02) 8519-5508

Any practice or policy previously circulated and implemented contrary to this document shall be considered superseded.
Enagic® reserves the right to revise, modify and amend any of these terms and conditions any time, and the
Buyer/Distributor agrees to abide by the most recent version of this Handbook.